

Resistance thermometers are used in the locations where precise temperature measurement is demanded in the industry. It is based on change of electrical resistance of conductor subject to the temperature. It is used the resistance detector that is wound from thin platinum or nickel wire insulated within enamel, glass or ceramic as conductor. Detector provides 100 ohm resistance output in 0 °C. Increasing or decreasing values of resistance subject to temperature are measured and then, temperature is detected. Copper, silver or nickel-chromium connection wires are added into two ends of resistance detector. It can be used from (-) 200 °C to (+) 850 °C. Analogue output information is taken through pt100 sensors in compliance with EN60751 and then, assessed in the automation system.

In order that resistance thermometers can measure accurately, it is recommended that it has dipping length as much as 6 and 15 times of dipping diameter.

Copper or Silver wire is used up to 500 °C and Nickel chromium is used after 550 °C between Pt 100 and connector. Copper conducting wire is used between device and pt100. It should have 2 wires up to 10 m. , 3 wires up to 150 m. and 4 wires after 150 m.

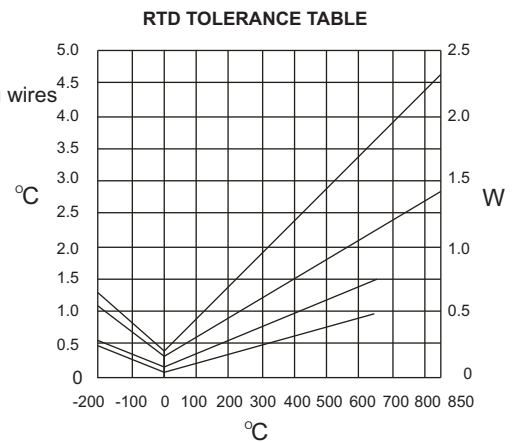
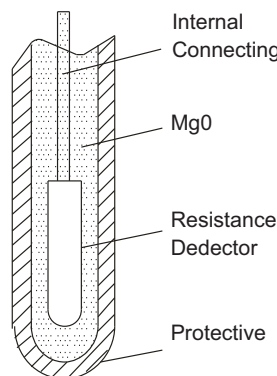

ETT TEMPERATURE SENSOR AND TRANSMITTER

- ETT 01 , ETT 02 , ETT 03 , ETT 04
- ETT 05 , ETT 06 , ETT 06p
- ETT 07 , ETT 08
- ETT 09 , ETT 09p , ETT 10 , ETT 10p
- ETT 11 , ETT 12 , ETT 13
- ETT 11m , ETT 12m
- ETT 21 , ETT 21p
- ETT 22 , ETT 23 , ETT 31

Advantages:

- * Models up to max. of 600 bar
- * Practical and economical
- * Digital display can be mounted

Areas of application :

Machines, tank, boilers, gas and liquid fluid, surface temp. measurement, ambient temperature measurement.



TEMP. °C	TOLERANCE EN 60751			
	A CLASS		B CLASS	
	±°C	±OHM	±°C	±OHM
-200	0.55	0.24	1.3	0.56
-100	0.35	0.14	0.8	0.32
0	0.15	0.06	0.3	0.12
100	0.35	0.13	0.8	0.30
200	0.55	0.20	1.3	0.48
300	0.75	0.27	1.8	0.64
400	0.95	0.33	2.3	0.79
500	1.15	1.38	2.8	0.93
600	1.35	1.43	3.3	1.06
650	1.45	1.46	3.6	1.13
700			3.8	1.17
800			4.3	1.28
850			4.6	1.34

Technical Specifications :

ETT 01

Type	In-Line
Range	(-) 50....(+) 650 °C
Mechanical Conn.	*
Electrical Conn.	Terminal
Sensor	1 x pt100 3 wire Class B (EN 60751)
Material	Stainless Steel
Stem Length (L)	On Request
Protection Class	IP 65
Pipe Diameter	6 / 9 / 11 / 14 mm



ETT 02

Type	In-Line
Range	(-) 50....(+) 650 °C
Mechanical Conn.	1/2" BSP (Std)
Electrical Conn.	Terminal
Sensor	1 x pt100 3 wire Class B (EN 60751)
Material	Stainless Steel
Stem Length (L)	On Request
Protection Class	IP 65
Pipe Diameter	6 / 9 / 11 / 14 mm

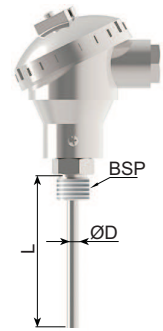

ETT 03

Type	In-Line
Range	(-) 50....(+) 650 °C
Mechanical Conn.	1/2" BSP (Std)
Electrical Conn.	Terminal
Sensor	1 x pt100 3 wire Class B (EN 60751)
Material	Stainless Steel
Stem Length (L)	On Request
Protection Class	IP 65
Pipe Diameter	6 / 9 / 11 / 14 mm



ETT 04

Type	In-Line
Range	(-) 50....(+) 650 °C
Mechanical Conn.	2" PN16 Flanged (Std)
Electrical Conn.	Terminal
Sensor	1 x pt100 3 wire Class B (EN 60751)
Material	Stainless Steel
Stem Length (L)	On Request
Protection Class	IP 65
Pipe Diameter	6 / 9 / 11 / 14 mm

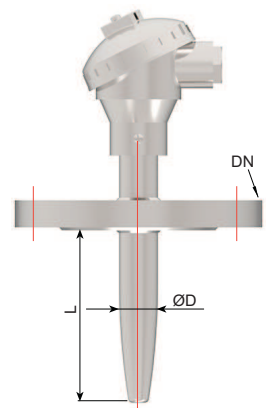

ETT 05

Type	Inset
Range	(-) 50....(+) 650 °C
Mechanical Conn.	1/2" BSP (Std)
Electrical Conn.	Terminal
Sensor	1 x pt100 3 wire Class B (EN 60751)
Material	Stainless Steel
Stem Length (L)	On Request
Protection Class	-
Pipe Diameter	6 mm

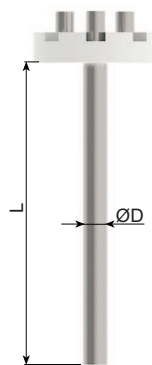

ETT 07

Type	In-Line
Range	(-) 50....(+) 800 °C
Mechanical Conn.	1" Clamp (Std)
Electrical Conn.	Terminal
Sensor	1 x pt100 3 wire Class B (EN 60751)
Material	Stainless Steel
Stem Length (L)	On Request
Protection Class	IP 65
Pipe Diameter	6 / 9 / 11 / 14 mm

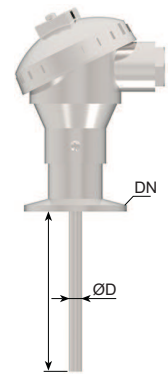

Technical Specifications :

ETT 06 ETT 06p

Type	In-Line
Range	(-) 30...(+) 200 °C
Mechanical Conn.	1/2" BSP (Std)
Electrical Conn.	PG9 Metal
Sensor	1 x pt100 3 wire Class B (EN 60751)
Material	Stainless Steel Opt.PTFE
Stem Length (L)	On Request
Protection Class	IP 68
Pipe Diameter	6 / 9 mm

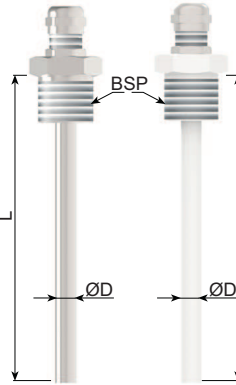

ETT 08

Type	In-Line
Range	(-) 30...(+) 200 °C
Mechanical Conn.	M10 x 1.5 mm
Electrical Conn.	Cable
Sensor	1 x pt100 3 wire Class B (EN 60751)
Material	Stainless Steel
Stem Length (L)	On Request
Protection Class	IP 68
Pipe Diameter	6 mm

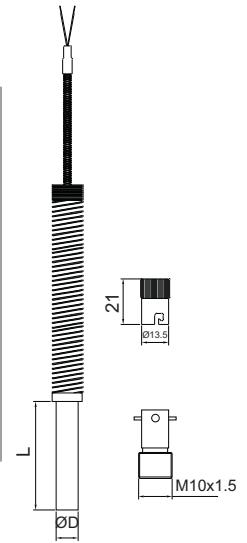

ETT 09 ETT 09p

Type	In-Line
Range	(-) 30...(+) 100 °C
Mechanical Conn.	1/2" BSP (Std)
Electrical Conn.	DIN 43650C
Sensor	1 x pt100 3 wire Class B (EN 60751)
Material	Stainless Steel Opt.PTFE
Stem Length (L)	On Request
Protection Class	IP 65
Pipe Diameter	6 mm

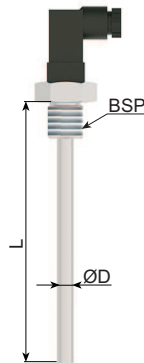

ETT 10 ETT 10p

Type	In-Line
Range	(-) 30...(+) 200 °C
Mechanical Conn.	1/2" BSP (Std)
Electrical Conn.	DIN 43650 (ISO 4400)
Sensor	1 x pt100 3 wire Class B (EN 60751)
Material	Stainless Steel Opt.PTFE
Stem Length (L)	On Request
Protection Class	IP 65
Pipe Diameter	6 / 9 mm

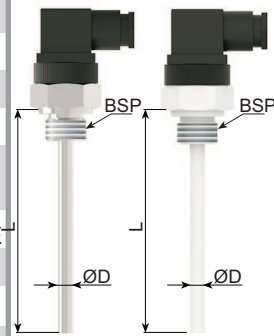

ETT 11 ETT12

Type	Wall
Range	(-) 40 °C...(+) 80 °C (0...80 °C Hole Type)
Electric Material	DIN 43650C
Sensor	1 x pt100 3 wire Class B (EN 60751)
Output	1 x pt100 or 4-20 mA 2 wire
Supply	10 - 30 VDC
Material	Stainless Steel
Stem Length (L)	50 mm (std)
Protection Class	IP 68
Pipe Diameter	6 mm

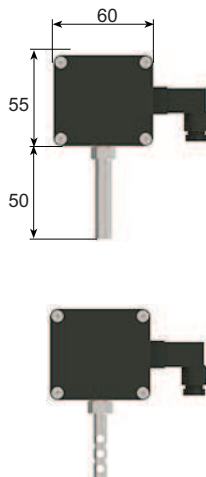

ETT13

Type	Wall
Range	(-) 40 °C...(+) 80 °C (0...80 °C Hole Type)
Electric Material	DIN 43650C
Sensor	1 x pt100 3 wire Class B (EN 60751)
Output	1 x pt100 or 4-20 mA 2 wire
Supply	10 - 30 VDC
Material	Stainless Steel
Stem Length (L)	50 mm (std)
Protection Class	IP 68
Pipe Diameter	6 mm

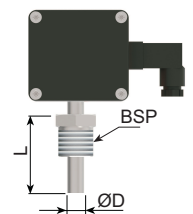

Technical Specifications :

ETT 11m

Type	Wall
Range	(-) 20 °C...(+) 80 °C (0...80 °C Hole Type)
Electric Material	With Cable
Sensor	1 x pt100 3 wire Class B (EN 60751)
Output	1 x pt100 or 4-20 mA 2 wire
Supply	10 - 30 VDC
Material	Stainless Steel
Stem Length	50 mm (std)
Protection Class	IP 68
Pipe Diameter (D)	6 mm



ETT 12m

Type	Wall
Range	(-) 20 °C...(+) 80 °C (0...80 °C Hole Type)
Electric Material	DIN 43650C
Sensor	1 x pt100 3 wire Class B (EN 60751)
Output	1 x pt100 or 4-20 mA 2 wire
Supply	10 - 30 VDC
Material	Stainless Steel
Stem Length	50 mm (std)
Protection Class	IP 65
Pipe Diameter (D)	6 mm



ETT 21

Type	In-Line
Range	(-) 50....(+) 200 °C
Mechanical Conn.	1/2" BSP (Std)
Electric Material	DIN 43650 (ISO 4400)
Sensor	1 x pt100 3 wire Class B (EN 60751)
Output	2 wire 4-20 mA std. 3 wire 4-20 mA, 0-20 mA 0-5 V, 1-5 V, 0-10 V
Supply	10 - 30 VDC
Material	Stainless Steel
Stem Length (L1)	On Request
Protection Class	IP 65
Pipe Diameter	8 mm

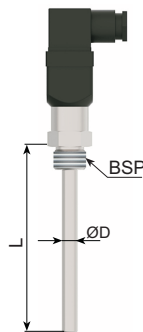

ETT 21p

Type	In-Line
Range	(-) 50....(+) 150 °C
Mechanical Conn.	1/2" BSP (Std)
Electric Material	DIN 43650 (ISO 4400)
Sensor	1 x pt100 3 wire Class B (EN 60751)
Output	2 wire 4-20 mA std. 3 wire 4-20 mA, 0-20 mA 0-5 V, 1-5 V, 0-10 V
Supply	10 - 30 VDC
Material	PTFE
Stem Length (L1)	On Request
Protection Class	IP 65
Pipe Diameter	8 mm

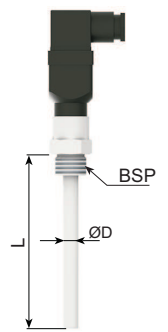

ETT 22 ETT 23

Type	In-Line
Range	(-) 50....(+) 200 °C
Mechanical Conn.	1/4" BSP (Std)
Electrical Material	DIN 43650 (ISO 4400)
Sensor	1 x pt100 3 wire Class B (EN 60751)
Output	2 wire 4-20 mA std. 3 wire 4-20 mA, 0-20 mA 0-5 V, 1-5 V, 0-10 V
Supply	10 - 30 VDC
Material	Stainless Steel
Stem Length (L)	25 mm
Protection Class	IP 65
Pipe Diameter	8 mm

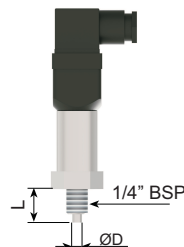

ETT 31

Type	In-Line - Prolonged
Range	(-) 50....(+) 650 °C
Mechanical Conn.	1/2" BSP (Std)
Electrical Material	DIN 43650A (ISO 4400)
Sensor	1 x pt100 3 wire Class B (EN 60751)
Output	2 wire 4-20 mA std. 3 wire 4-20 mA, 0-20 mA 0-5 V, 1-5 V, 0-10 V
Supply	10 - 30 VDC
Material	Stainless Steel
Stem Length (L)	On Request
Protection Class	IP 65
Pipe Diameter	8 mm

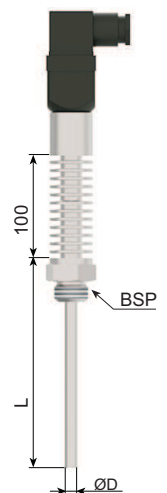

Mechanical Connection :

Thread

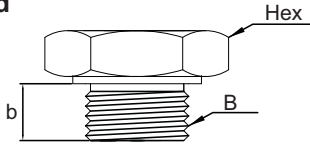

Flanged

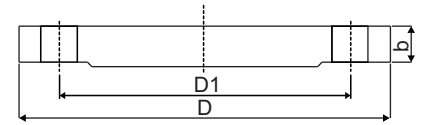

(ISO228-1)

Order Code	Measure B	Hex (mm)	Thread	Lenght b (mm)
001	1/8" BSP	17		12
002	1/4" BSP	17		12
003	3/8" BSP	24		20
004	1/2" BSP	27		14
005	3/4" BSP	32		14
006	1" BSP	41		23
007	1 1/4" BSP	51		23
008	1 1/2" BSP	60		23
009	2" BSP	70		23

Order Code	(ISO1092-1) PN 16	D (mm)	D1 (mm)	b (mm)
103	DN 25	165	85	16
104	DN 32	140	100	16
106	DN 50	165	125	18
108	DN 80	200	160	20
109	DN 100	220	180	20

Order Code	(ISO1092-1) PN 40	D (mm)	D1 (mm)	b (mm)
303	DN 25	115	85	18
304	DN 32	140	100	20
306	DN 50	165	125	20
308	DN 80	200	160	20
309	DN 100	235	190	24

Order Code	(ANSI B16.5) 150 LBS	D (mm)	D1 (mm)	b (mm)
606	DN 50	152,4	121	19
607	DN 65	177,8	139,7	22,2
608	DN 80	190,5	152,4	23,8
609	DN 100	228,6	157,2	23,8

Clamp

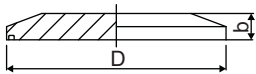

Order Code	(ISO2852) Measure	D (mm)	b (mm)
851	DN 32	50,5	15
852	DN 50	64	17
853	DN 65	91	17

Dairy

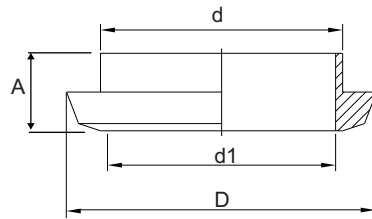

Order Code	Measure	Dia.	D (mm)	d1 (mm)	A (mm)
870	DN 40	DN 40	56	48	13
871	DN 50	DN 50	68	61	14
872	DN 100	DN 100	121	114	20

RTD CABLES

Different section copper wires are used between resistance thermometer and device. The section of wires is important. Generally, 0,2 OHM resistance, 2 x 1,5 mm section copper wires are preferred. Up to 10 m. 2 wires, up to 150 m. 3 wires, over 150 m. 4 wires cable should be used.

ETK - RTD - Silicon - With Silicon Isolation - 2 Damarlı - 1.5 mm Sectioned - numerous wires

Thermowell ELX 51, 52, 53, 54

(Can be produced using requested dimensions and materials.) **Please see detailed instructions.**

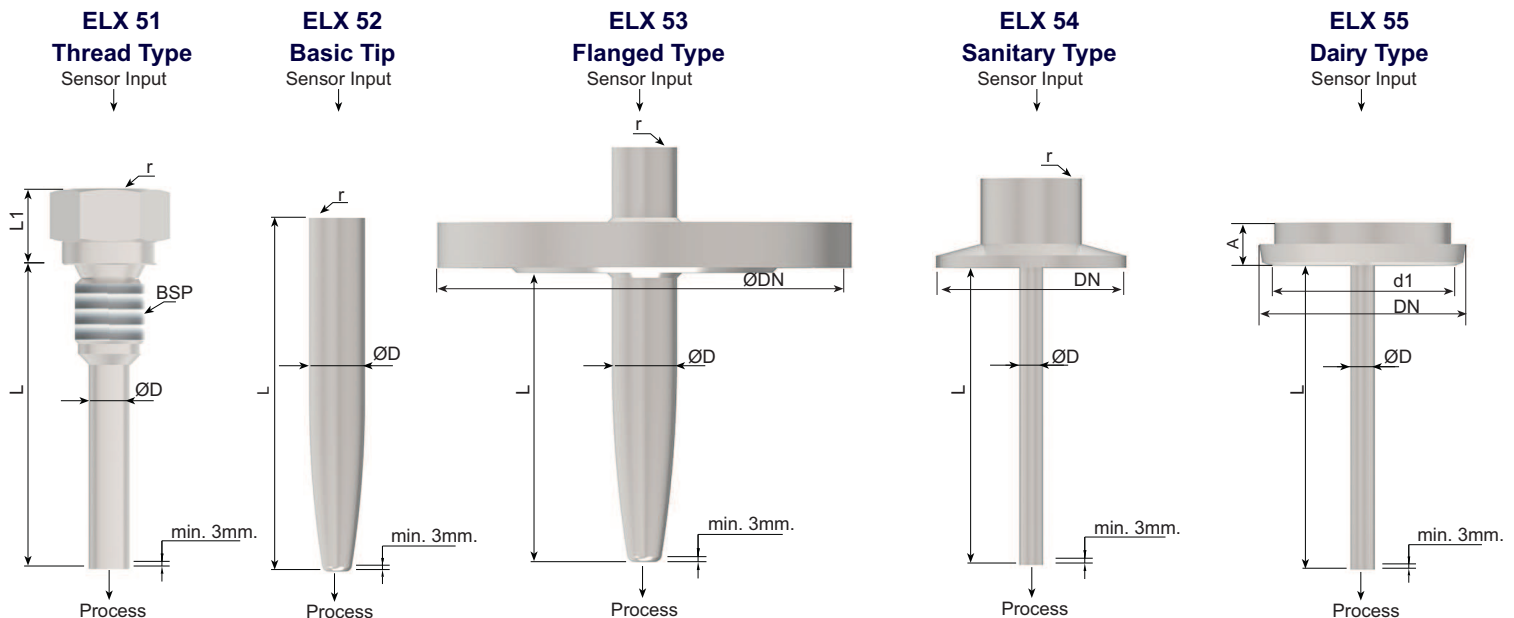

Electric Connection :

**ETT 11, ETT 12 , ETT 13
ETT 21, ETT 21p, ETT 22, ETT 23
ETT 31 (2 wire)**

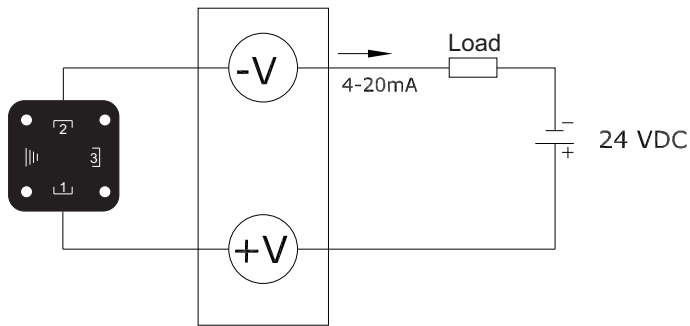

**ETT 11, ETT 12 , ETT 13
ETT 21, ETT 21p, ETT 22, ETT 23
ETT 31 (3 wire)**

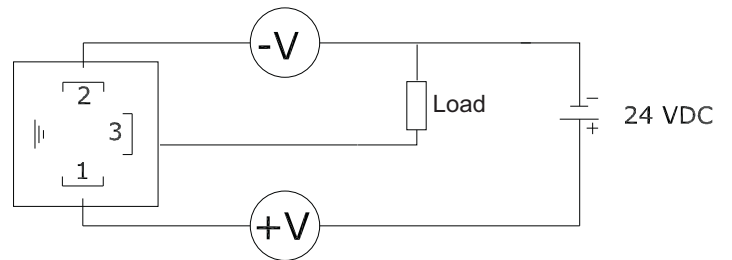

ETT 09, ETT 09p, ETT 10, ETT 10p

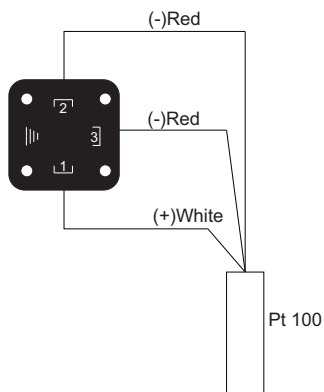

ETT 01, ETT 02, ETT03, ETT04, ETT05, ETT 07

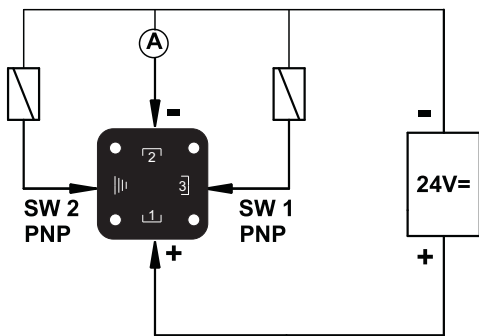
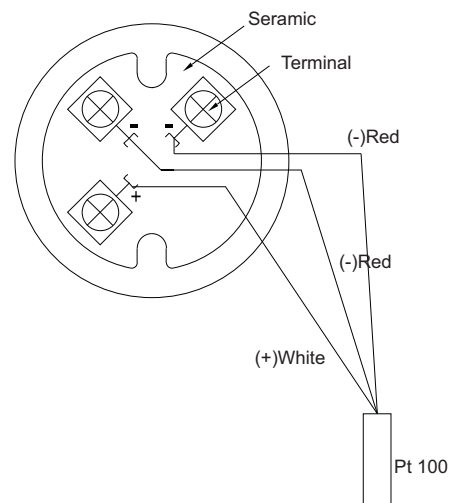

4-20 mA Two Wire + 2 PNP

EDS 01

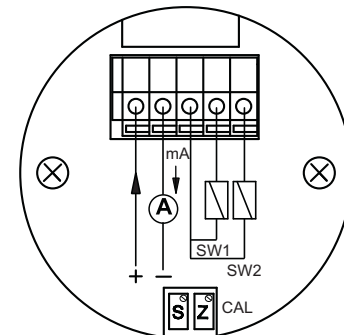

4-20 mA Two Wire + 2 PNP NA

EDS 02

Order Form : Please consider sample models when coding!..

1 MODEL

ETT 01	ETT 06	ETT 09	ETT 11	ETT 21	ETT 22
ETT 02	ETT 06p	ETT 09p	ETT 11m	ETT 21p	ETT 23
ETT 03	ETT 07	ETT 10	ETT 12		ETT 31
ETT 04	ETT 08	ETT 10p	ETT 12m		
ETT 05			ETT 13		

(B Type For ETT01 , 02 and 03 ; Aluminum Casting, Painted, Housing is used.)

2 CERTIFICATE

None.....0	(EN10204-3-1) Material Certification.....1
------------	--

3 HOUSING

None.....00	Aluminium Housing, B20x25
Plastic Housing , B10p01	Aluminium, Double Cover (B010).....26
Plastic Housing, B20p02	Alüminyum , B035.....27
Aluminium Housing , B10x24	Stainless Steel Housing , B101x.....41
	Special.....x

4 ELECTRICAL CONNECTION

Terminal (For Housing Models).....00	M12-2 Pin.....70
Polyamide Big Socket P01.....50	M12-5 Pin.....71
Polyamide Small Socket P02.....51	M12-8 Pin.....72
Polyamide Big Light Socket P03.....52	PVC Cable (Max. 60 °C).....80
Military Socket ML-2 , 2 Pin.....60	PVC Cable (Max. 105 °C).....81
Military Socket ML-5 , 5 Pin.....61	Silicon Cable (Max. 200 °C).....82
	PTFE Cable (Max. 230 °C).....83
	Special Cable.....x
	Special Socket.....x

5 NUMBER OF SENSOR

Single Sensor.....1	Double Sensor.....2
	Special.....x

6 OUTPUT

4-20 mA Two Wire.....19	Pt-100 (Sınıf A)41
4-20 mA Three Wire.....20	Pt-100 (Sınıf B).....42
0-10 V Three Wire21	Special.....x
0-20 V Three Wire.....22	

7 CONNECTION MEASUREMENT

1/4"BSP.....002	DN 25 PN40 Flanged ISO 1092-1.....303
1/2"BSP.....004	DN 32 PN40 Flanged ISO 1092-1.....304
3/4"BSP.....005	DN 50 PN40 Flanged ISO 1092-1.....306
1"BSP.....006	DN 80 PN40 Flanged ISO 1092-1.....308
M10 x 1,5.....082	DN 100 PN40 Flanged ISO 1092-1.....309
DN 25 PN16 Flanged ISO 1092-1.....103	DN 50 ANSI 150 Flanged606
DN 50 PN 6 Flanged ISO 1092-1.....106	DN 80 ANSI 150 Flanged608
DN 25 Clamp ISO 2852.....850	DN 100 ANSI 150 Flanged609
DN 32 Clamp ISO 2852.....851	Special.....x
DN 50 Clamp ISO 2852.....852	
DN 65 Clamp ISO 2852.....853	

8 CONNECTION MATERIAL

304 Stainless Steel.....	.01	Delrin.....	.63
316 Stainless Steel02	PVDF.....	.64
Brass.....	.41	PBT.....	.65
PVC.....	.61	PTFE.....	.66
Polypropylene.....	.62	Special.....	.x

9 PROTECTIVE SHEATING DIAMETER (PIPE SIZE)

6 mm.....	.06	12 mm.....	.12
8 mm.....	.08	14 mm.....	.14
9 mm.....	.09	15 mm.....	.15
11 mm.....	.11	22 mm.....	.22
		Special.....	.x

10 EXTERNAL PROTECTIVE TUBE

None.....	.00	321 Stainless Steel.....	.05
304 Stainless Steel.....	.01	PTFE.....	.66
316 Stainless Steel.....	.02	Special.....	.x

11 STEM LENGHT

15 mm.....	.01	400 mm.....	.40
25 mm.....	.02	500 mm.....	.50
50 mm.....	.05	710 mm.....	.71
100 mm.....	.10	1000 mm.....	.100
160 mm.....	.16	1200 mm.....	.120
200 mm.....	.20	1500 mm.....	.150
250 mm.....	.25	Special.....	.x
300 mm.....	.30		

12 OPTİONAL

None.....	/ 0	Double Cell Digital Display.....	/ EDS 02
Cooling.....	/ 1	Termovel.....	/ ELX ??
Local Digital Display	/ EDS 01	Special.....	.x

SAMPLE

ETT 02 - 0 - 25 - 00 - 1 - 19 - 004 - 01 - 08 - 00 - 05 / 0
ETT 02 4-20 mA , 304 Stainless Steel , 1/2" BSP , Ø 8 mm , L= 500 mm