

ECAPm level transmitter is a capacitive level sensor for level measurement of conductive liquid, nonconductive liquid, granulated materials with solid particles, adhesive and acid/basic liquids.

When a material comes between electrode rod and tank wall, a capacitance change occurs and when this change exceed adjustment threshold, contact output is delivered.

Full-empty calibration can be performed easily and safely.

Different designs and different solution related to industrial level measurement are offered especially for machinery manufacturers.

Application Areas

Liquid tanks, food machines, cooling liquid tanks, shipping, glycol tanks, brine, waste water tanks.

Oil tanks, CO₂ liquid tanks, high temperature tanks, non-conductive liquids.

Grain stores, cement, sand feed, flour, milk powder, organic and plastic granule.

Sticky hot and high viscosity liquid, acid and chemical liquids.



ECAPm

CAPACITIVE LEVEL TRANSMITTER

ECAPm 101

ECAPm 203

ECAPm 305

ECAPm 408B , 408T , 408Tm

- * There are no moving parts.
- * High pressure and temperature resistant design.
- * Modular structure with easy assembly.
- * Not affected by foam, liquid splashes.
- * Not affected by vibration, has robust mechanical structure.
- * Zero span adjustment is easy.
- * Measurement along whole sensor.
- * Operability with reverse assembly.



Technical Specifications:

Measurable Material	Conductive liquids Low conductive liquids Solids particulate materials Adhesive and acid/basic liquids
Supply	9...36 VDC
Signal Output	4-20 mA two wire Std. 0-20 mA - 4-20 mA, 0-10 V three wire Opt.
Accuracy	± % 0,5 , ± % 0,8 , ± % 1
Linearity	% 0,5
Capacity Range	1 pF...3 nF
Min. Di-Electric Constant	1,6 ϵ_r
Connection Material	304 St.St. Opt. 316 St.St.
Isolation Material	PFA Std.Opt. PTFE
Housing Material	Aluminium
Working Pressure	Max.150 bar (Depending on the model)
Working Temperature	(-) 30 °C / (+) 150 °C (Depending on the model) 200 °C with cooling apparatus
Ambient Temperature	(-)20 °C / (+) 60 °C
Display	With LED-Power and Contact LED
Power Consumption	Max. 50 mW
Electrical Connection	Treminal
Protection Class (EN60529)	IP 65
Test	EMC, Low voltage
Max.Tensile Force	Max. 40 Nm
Weight	1000 g. for ECAPm 101 250 mm

Working Principle :

Capacitance definition, assuming two parallel conductive plates are used;

$$C = \frac{\epsilon_0 \cdot \epsilon_r \cdot S}{d}$$

C: Capacity , Farad
 S: Surface Area , m²
 d: Distance , m

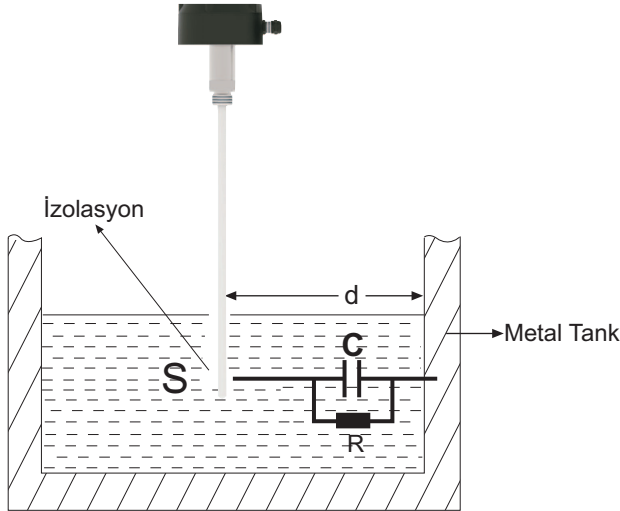

However, there are scarcely any sensor type which this definition can be practically utilized. Above Formula can no longer be reliable especially when residual areas increase due to large distance (d) (which is usually the case). Thus, measuring impedance for distance measurements give more accurate results than capacitance measurement.

Excitation applied between 10KHz...250KHz based on length for all our models. $\varphi = 2\pi \cdot f \cdot l$ Linearity error that may be caused by conductivity component (R) effect is prevented by electronic circuit design and mechanical design. Reduced to a level lower than 1ppm, acceptable as zero.

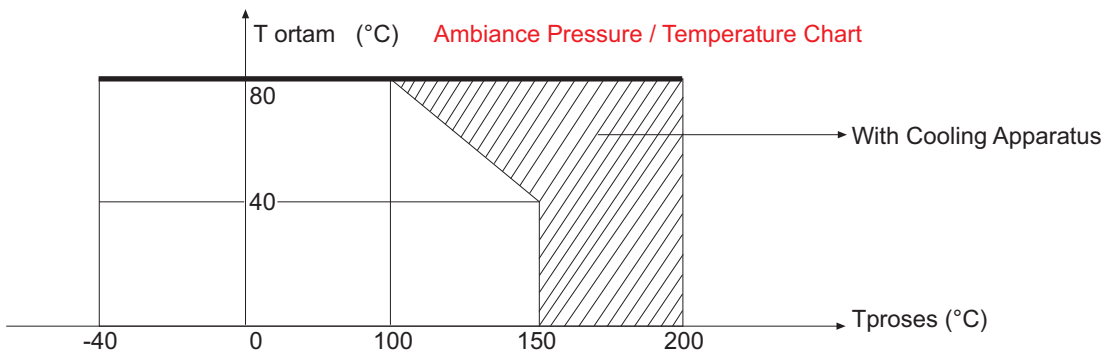
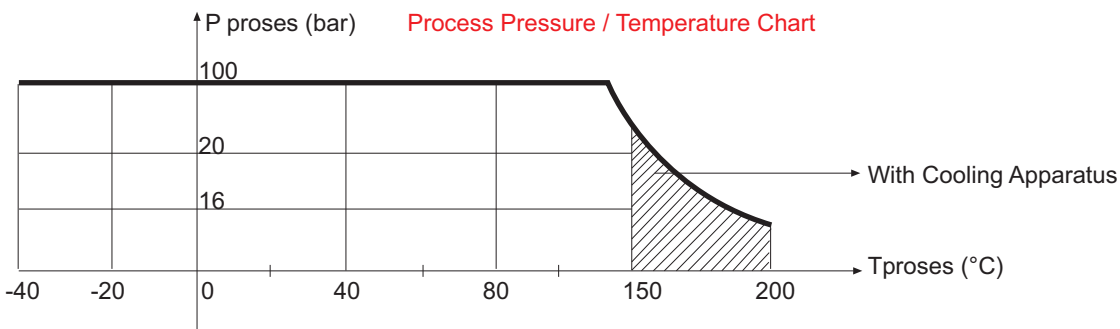
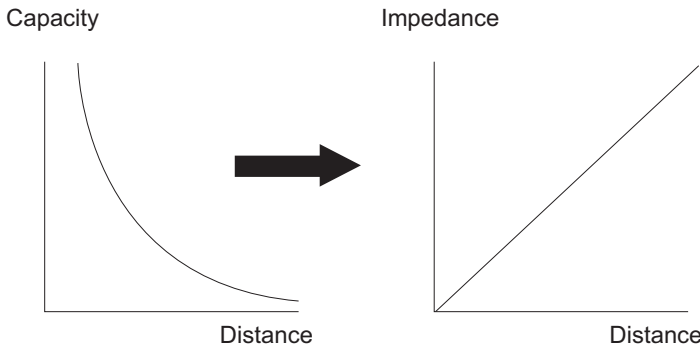

Application Examples :

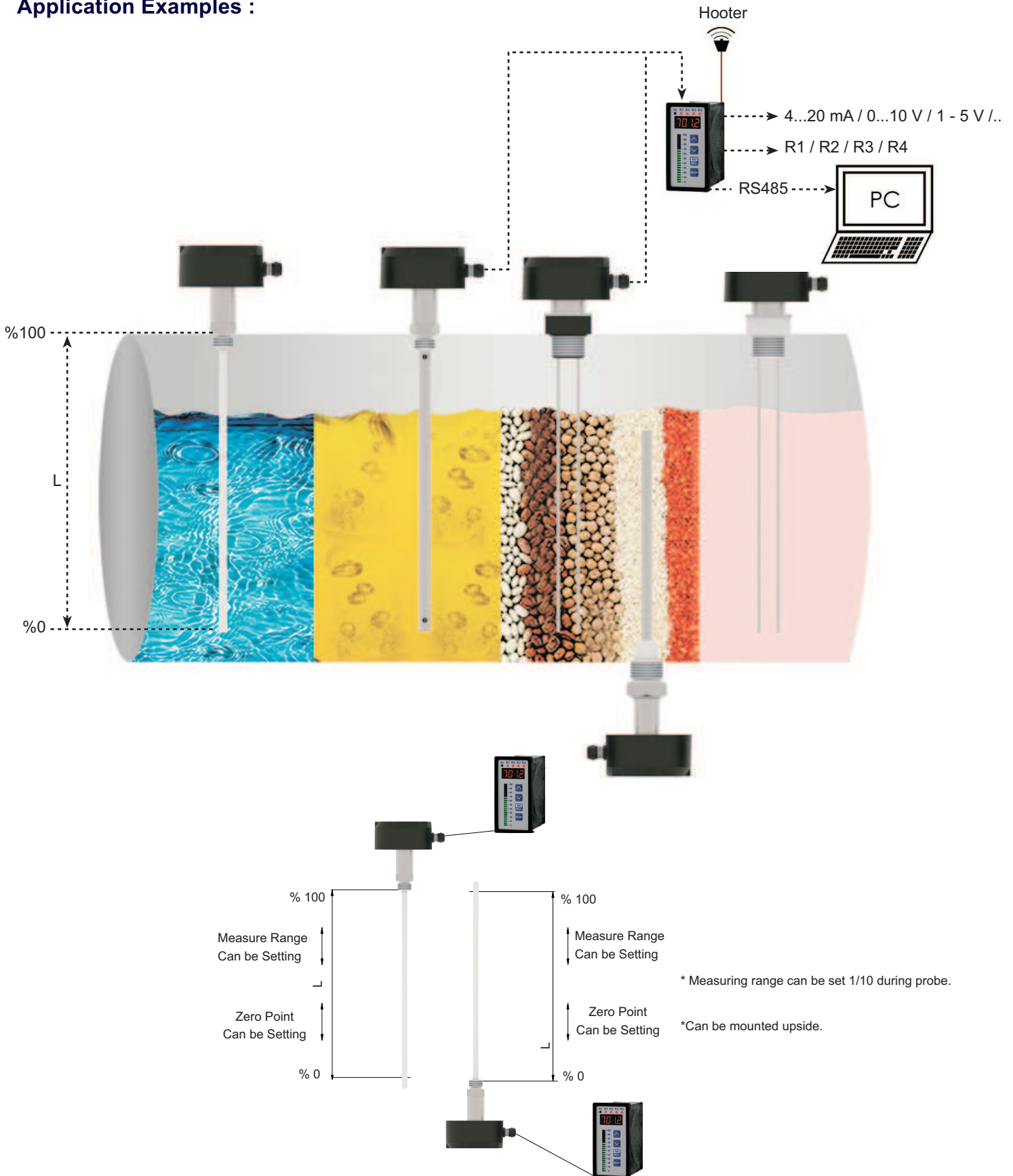

Parts :

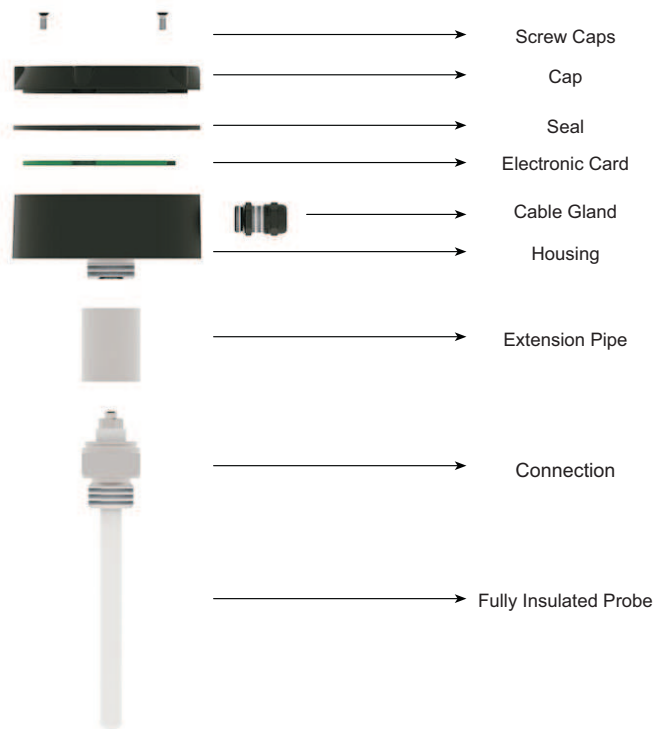

Electrical Connection :

4-20 mA Two Wire

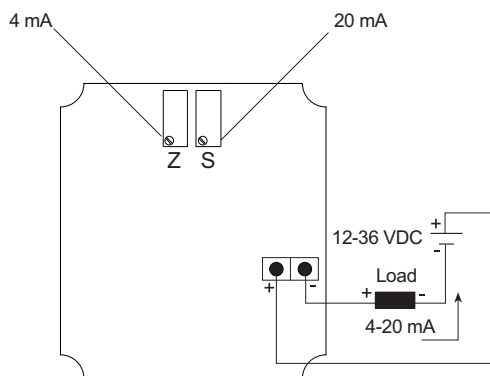

4-20 mA / 0-20 mA Three Wire

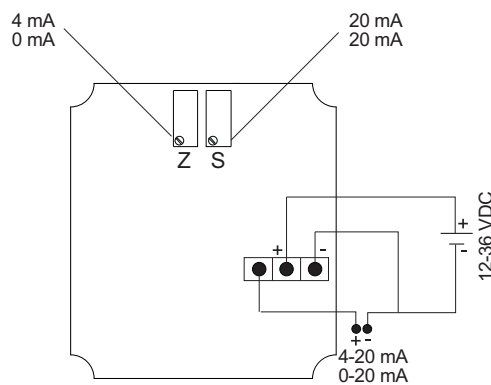

0-10 V Three Wire

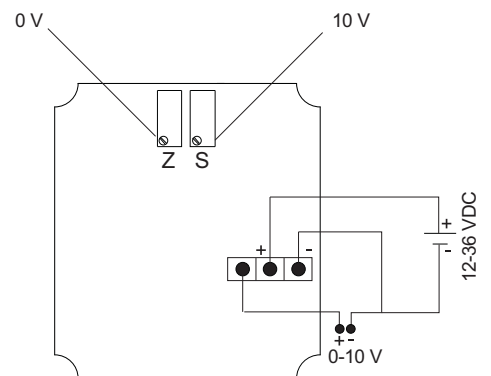

Calibration :

Z: Measuring starting point - 4 mA (zero)

S: Measuring peak point - 20 mA (span)

Zero adjustment (z): 4 mA adjustment is performed at factory exit, assuming tank is completely empty. If adjustment is needed again, 4mA output adjustment can be performed by Z trimmer after the tank is filled until initial level.

Measurement field (span) adjustment: 20 mA is adjusted at factory exit, assuming tank is filled up to length of electrode.

If adjustment is needed again, 20 mA output adjustment can be performed by S trimmer after filling the tank up to a desired level.

Housing :

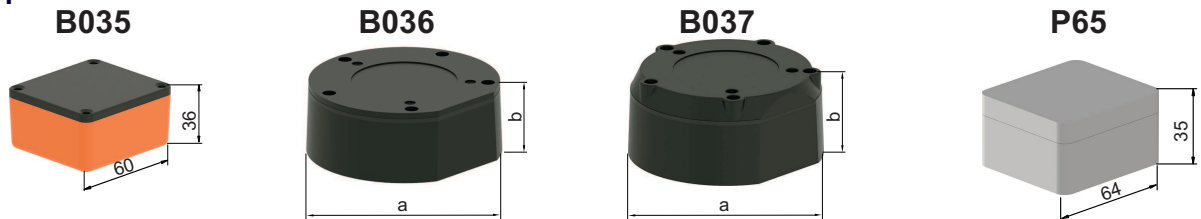

ORDER CODE	TYPE	MATERIAL	PROTECTION CLASS	TEMPERATURE (°C)	SIZE a x b x c (mm)
310	B035	Aluminium	IP 65 With Seal	(-) 30...(+) 150	60 x 55 x 30
201	P65	PC	IP 65	(-) 20...(+) 80	64 x 58 x 35
036	B036	Plastic	IP 65	(-) 30...(+) 100	Ø 93 x 35
039	B037	Plastic	IP 65	(-) 30...(+) 100	Ø 93 x 43

Mechanical Connection :

Thread

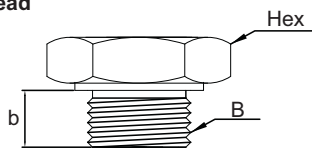

(ISO228-1)

Dimension B	Hex [mm]	Screw Length b [mm]
1/2" BSP	27	14
3/4" BSP	32	14
1" BSP	41	23
1 1/4" BSP	51	23
1 1/2" BSP	60	23
2" BSP	70	23

Electronic Unit with Cable:

Electronic unit and sensor component can be separated by a cable protected against exterior conditions for easy calibration on site. Cable provides easy assembly for user by its property not affecting capacitive measurement.

Sample Model :



Cooling :

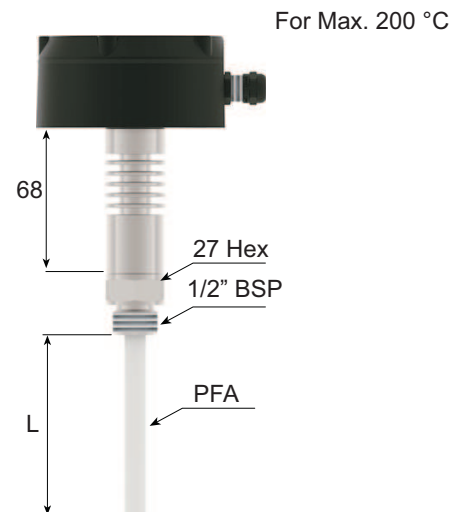

Sample Models :

CONDUCTIVE LIQUIDS

ECAPm 101

Fully Insulated Probe
Conductive Tank

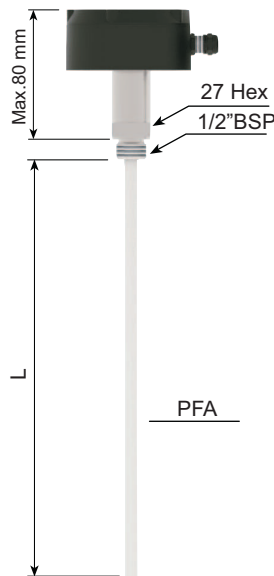

L=Max. 1 m.
(-) 1 bar...(+) 150 bar
Max. 150 °C

LOW CONDUCTIVE LIQUIDS

ECAPm 203

Coaxial Probe
Conductive / Insulating Tank



L=Max. 1 m.
(-) 1 bar...(+) 100 bar
Max. (+) 150 °C

SOLID PARTICLE LIQUIDS

ECAPm 305

Partly Insulated Probe
Conductive Tank

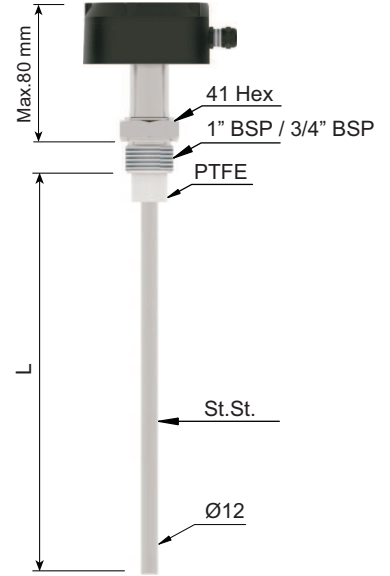

L=Max. 1 m.
(-) 1 bar...(+) 60 bar
Max. (+) 150 °C

**ADHESIVE AND
ACID / BASIC LIQUIDS**

ECAPm 408B

Double Probe - Non Insulated
Conductive / Insulating Tank

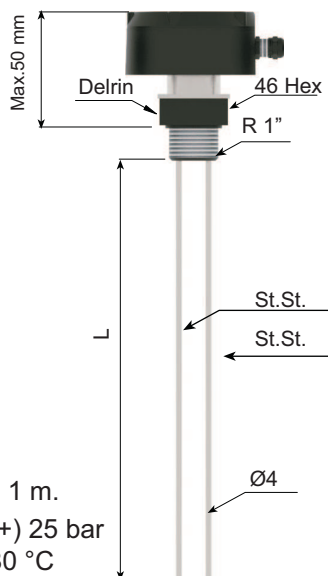

L=Max. 1 m.
(-) 1 bar...(+) 25 bar
Max. 80 °C

**ADHESIVE AND
ACID / BASIC LIQUIDS**

ECAPm 408Tm / 408T

Double Probe - Non Insulated
Conductive / Insulating Tank

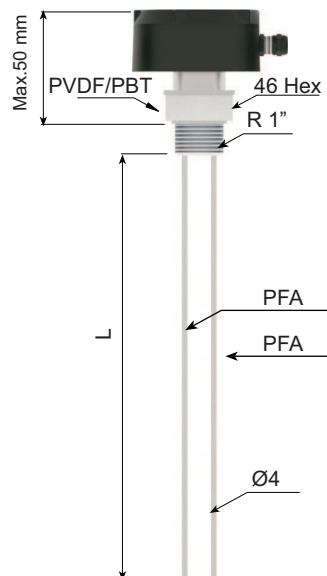

L=Max. 1 m.
(-) 1 bar...(+) 25 bar
Max. 120 °C / 150 °C

Order Form : Please consider sample models when coding.

1 MODEL ECAPm

Conductive Liquids.....1	Solids Particulate Materials.....3
Low Conductive Liquids2	Adhesive and Acid/Basic Liquids.....4

2 CERTIFICATE

No0	(EN10204-3-1) Material Certification.....1
-----------	--

3 PROBE TYPE

Single Probe - Insulated (Max.1 m.)1	Double Probe - Without Partly Insulated (Max.1 m.).....8B
Coaxial Probe (Max 1 m.) ...Ø 13 or 21 mm.....3	Double Probe - Double Insulated (Max.1 m.).....8T
Single Probe - Partly Insulated (Max.1 m.) 5	Double Probe - Double Fully Insulated (Max.1 m.).....8Tm
	Special.....x

4 STEM LENGHT

.....mm0

5 PROCESS TEMPERATURE

150 °C Standard0	80°C For Plastic (Delrin) Model.....2
200 °C with Cooling Apparatus1	120°C For Plastic (PVDF) Model3
	150°C For Plastic (PBT) Model.....4

6 CONNECTION

Thread (ISO 228-1)

1/2" BSP004	1 1/2" BSP008
3/4" BSP.....005	2" BSP009
1" BSP.....006	Special.....x
1 1/4" BSP.....007	

7 OUTPUT

4-20mA Two Wire.....19	Special.....x
4-20mA Three Wire.....20	
0-10V Three Wire.....21	
0-20mA Three Wire.....22	

8 HOUSING

Aluminium , B035.....310	Plastic , For B036 OEM036
PC , P65.....201	Plastic , For B037 OEM039
	Special.....x

9 INSULATION MATERIAL

PBT.....65	Polyamide.....69
PTFE.....66	Seramic.....70
PFA.....67	Rubber.....81
PEEK.....68	FKM.....84
	Special.....x

10 CONNECTION MATERIAL

316 Stainless Steel.....02	PVDF.....64
Brass.....41	PBT.....65
Polypropylene.....62	PTFE.....66
Delrin.....63	Special.....x

11 ELECTRICAL CONNECTION

Terminal.....00	Silicone Cable (Max.200 °C).....82
PVC Cable (Max.105 °C).....81	Special.....x

12 OPTIONAL

No...../ 0	Seperable Electronic Unit...../ S
By - Pass Tube...../ T	Wall Apparatus...../ W
	Special.....x

SAMPLE

ECAPm - 101 - 300mm - 0 - 006 - 21 - 310 - 17 - 02 - / 0
 For Cond. Liquid, L=300 mm, 1" BSP, 0-10 V, Aluminium Housing

