

Level switch with DX-ELF motor is used for level control in silos and tanks where materials with solid particles are stored. Full and empty signals can be received by performing level control in many demanding applications with different probe and pedal varieties in a safe manner. It can be connected horizontally and vertically.

Working Principle:

A palette selected according to the material is installed on the tip of the motorized level switch which can be installed on the tank wall. It revolves idly with the revolution speed of the probe motor. Material to be detected reaches to the level of the palette and covers its circumference and creates a counter-force according to the revolution force. Firstly, level information alarm contact is activated. Then, the other contact is triggered and stops the motor. Adjustment of the spring in four different torque values according to specific weight of the material can be realized by the user. When the material level at the end of the palette is decreased the created force is released and the motor starts to revolve, consequently, changing the alarm position.

Applications ;

Plastic Industry ; PVC, PVDF, PP granular etc..

Food Industry ; Grain Dust, Ground Corn, Sugar-Granulated, Cacao, Malt-Graoung Dry, Sunflower Corn, Whead, Peanuts-Shelled, Clays- Kaoline, Talcum Powder, Ground-Paprika, Coffee-Roasted vb..

Build Industry ; Rocks-Limestone Crushed, Lime, Cement Powder, Rubber Ground, Lime Hydrate Dust, Calsium Dust, Iron Chips, Silica Sand, Moulding Sand, Styrofaam etc..

Wood Industry ; Wooden Fiberst, Saw Dust etc..

Other Chemistry Industry ; Coal Lump, Ash-Coal Dry etc..



Certification



II 1/2 G Ex d IIC Tx*1 Ga/Gb For Gas

II 1/2 D Ex (ta/tb)*3 IIC Tx*2 For Dust

*Have a look at the temperature class chart.

Technical Specifications :

Working Temperature (TP)	(-) 20 °C(+) 90 °C (-) 20 °C(+) 60 °C (For Plastic Connection Models) Opt. Max.150 °C With High Temperature Type Max.200 °C With High Temperature Type
Ambient Humidity	0-98 % Rh (Non Condensate)
Ambient Temperature (Ta)	(-) 20 °C ... (+) 60 °C
Working Pressure	(-) 0,6 bar ... (+) 0,6 bar
Material Connection	Aluminium Opt. 304 / 316 Stainless Steel
Housing	Aluminium Enjection - AlSi12Fe (Std) Black (RAL:9005)
Paddle And Rode	304 Stainless Steel, (Std) Ops. 316 Stainless Steel
Extension Pipe	304 Stainless Steel, (Std) Ops. 316 Stainless Steel
Grounding Apparatus	304 Stainless Steel
O-Ring for Cover	Elastomer Thermoplastic 120°C (Std) Ops.FPM (Viton) 150°C
Bearing	Dust Protected Double Begring (120 °C) Ops. 280 °C
Dust Protected Felting	NBR (Std) Opt. FPM (Viton) 150 °C, PTFE 200 °C
Connection	1" BSP (Std) , Opt. 1 1/4" BSP , 1 1/2" BSP Male Thread
Power Consumption	Max. 4W (220 VAC) , Max.3W (24 VDC)
Revolutions Per Minute	5 d/d (Std) (Clockwise - When Looking Paddle Side) Opt. 1,5-1,8 d/d
Power Supply	24 VDC ± % 10 , 24 / 48 / 110 / 220 VAC 50 / 60 Hz ± % 10
Cable and stopper input	M20 x 1,5 (Std)
Relay switching capacity	10 A / 250 VAC - 4 A / 30 VDC 2 x NANK (SPDT) 5E4
LED	Power LED: Green , Alarm LED: Red
Max. Grain Structure	50 mm
Min. Density	0,04 g/cm³ (According to paddle type)
Torque Rating	4 Stages, adjustable
Load on probe	Max. 500 N (Extention Pipe)
Protection Class	IP 66 (EN60529)
Certification	CE Declaration , EMC , LVD , ATEX

DX-ELF ROTARY LEVEL SWITCH

- DX-ELF 101
- DX-ELF 102
- DX-ELF 103
- DX-ELF 103p
- DX-ELF 104
- DX-ELF 105
- DX-ELF 106
- DX-ELF 106m
- DX-ELF 108
- DX-ELF 109

Advantages :

- * Fast Delivery Time
- * Reverse Rotaion Safety
- * Sensitivity Adjustable
- * Excellent Mechanical



Parts:

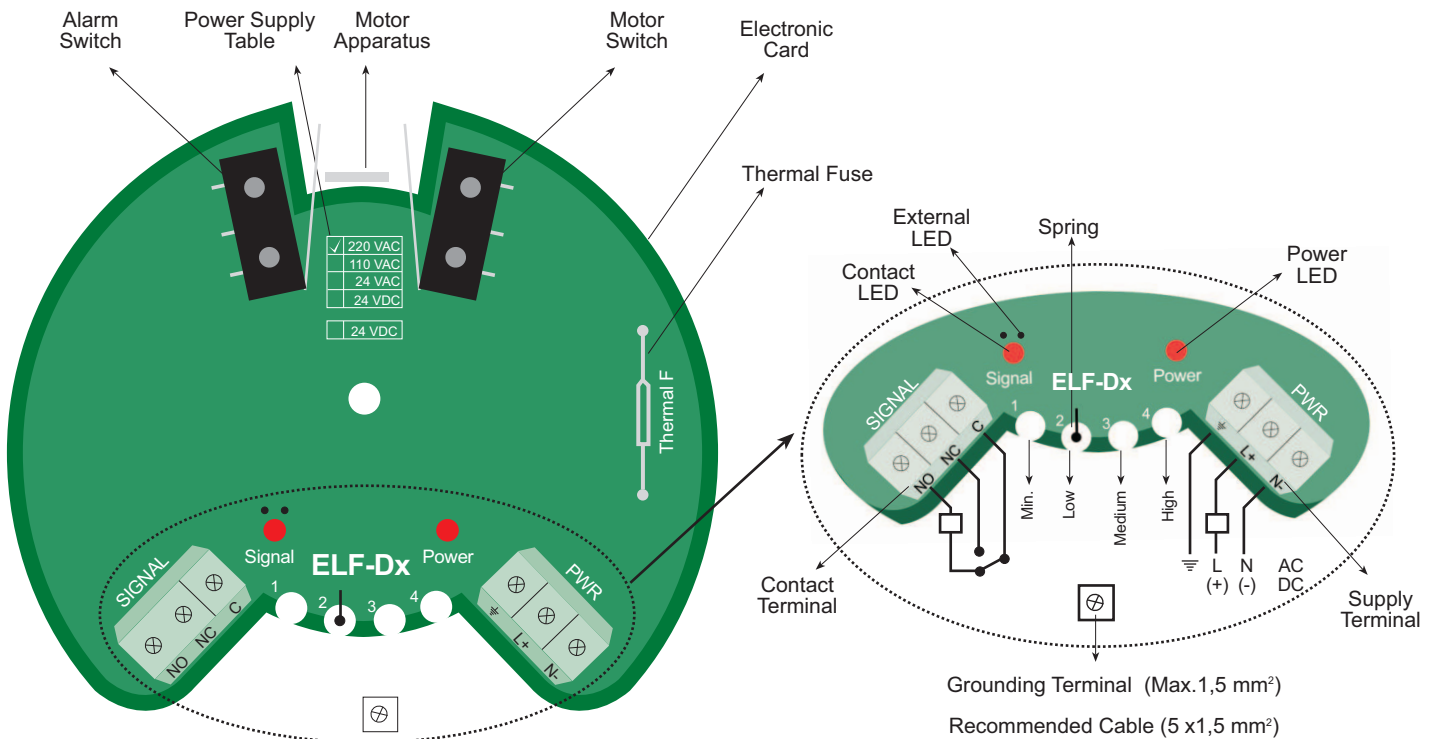
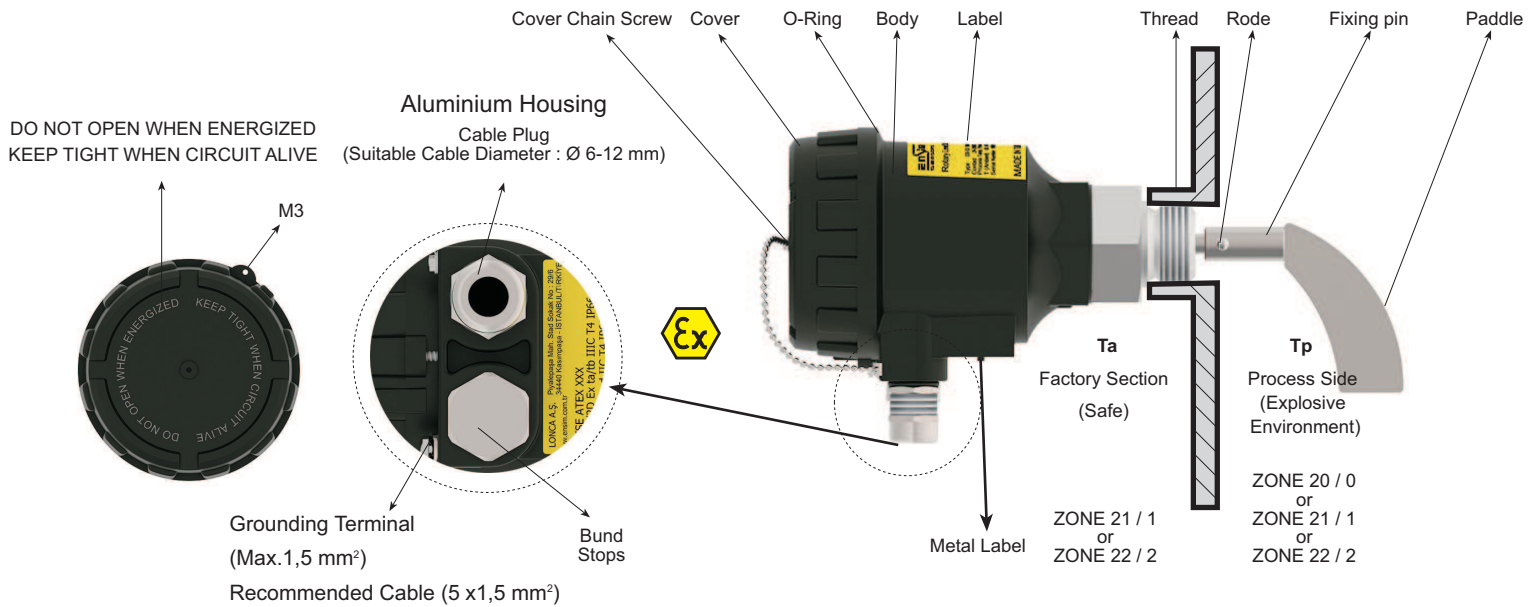

Note : It has been produced according to IPC A 600 class 2 conditions and tested with 100 % E-test. Moreover, HASL (non-lead) surface test has been applied.

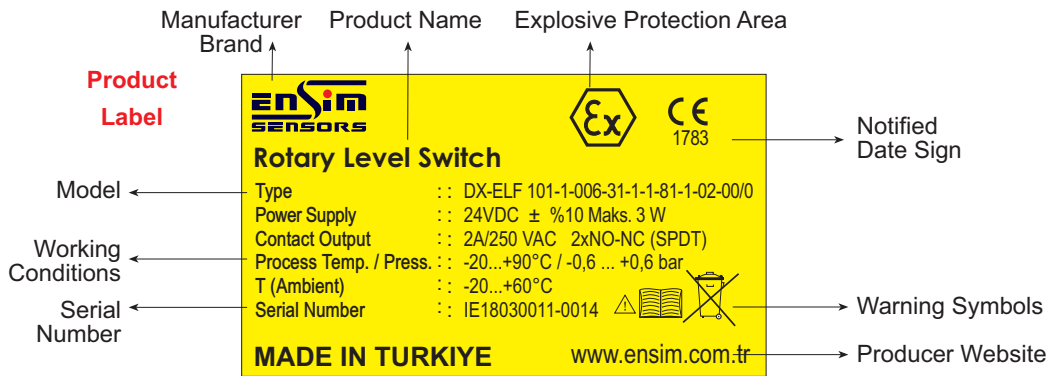

MODULAR STRUCTURE :

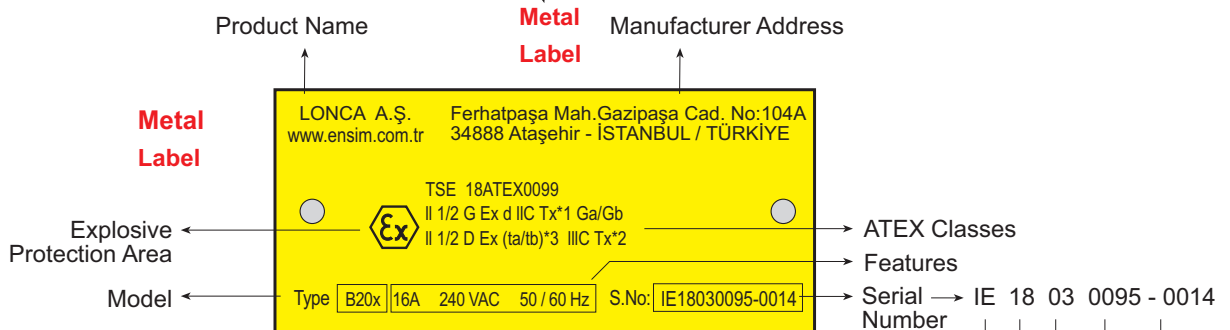
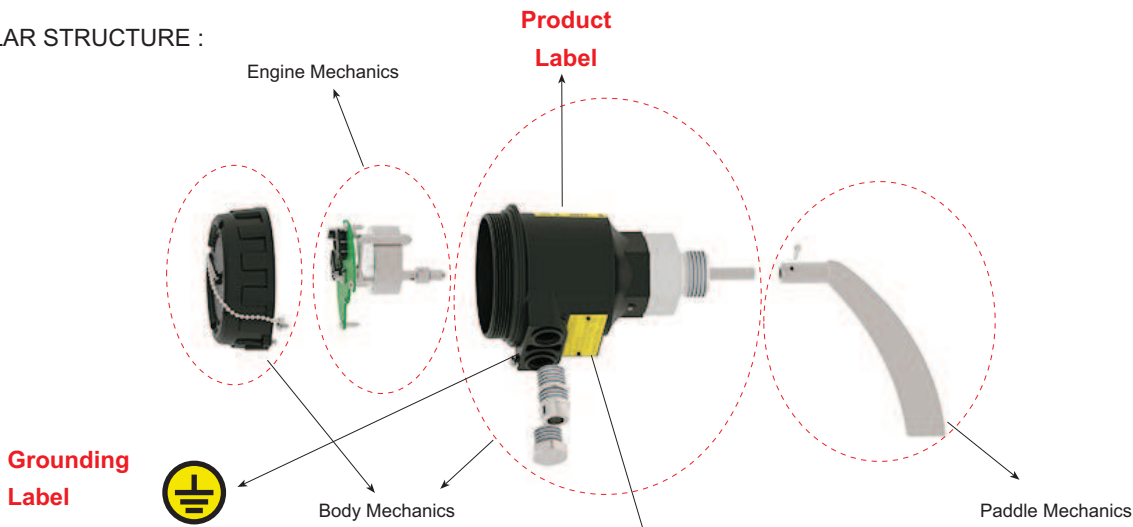

Note : If the ATEX certificate metal label is damaged, you can contact the manufacturer with the serial number.

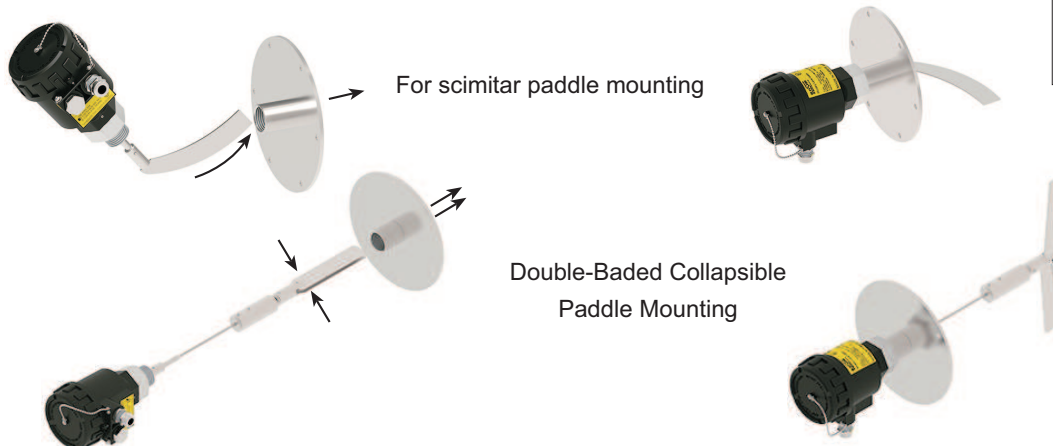
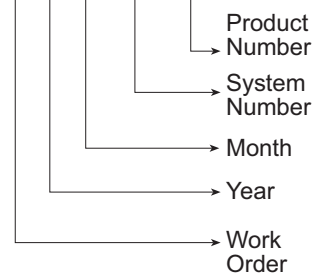

Example Mounting Types :

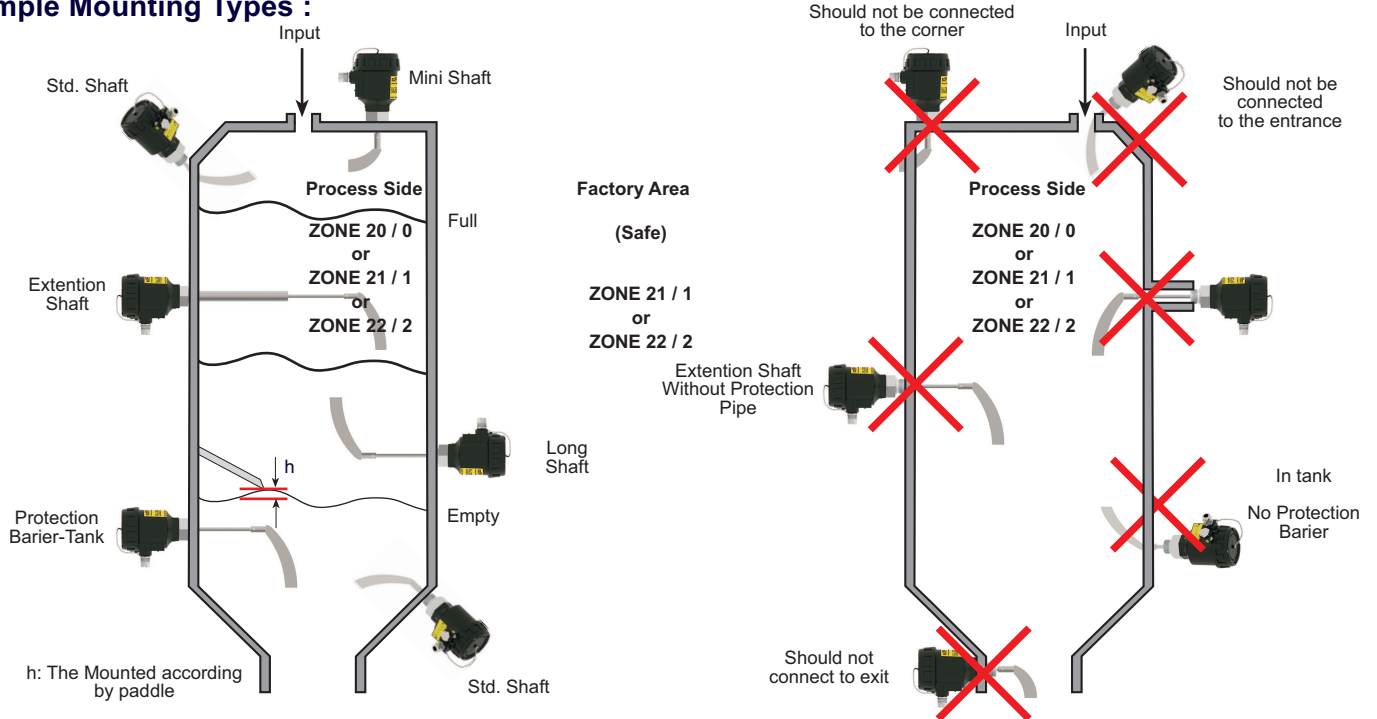

Switching Logic :

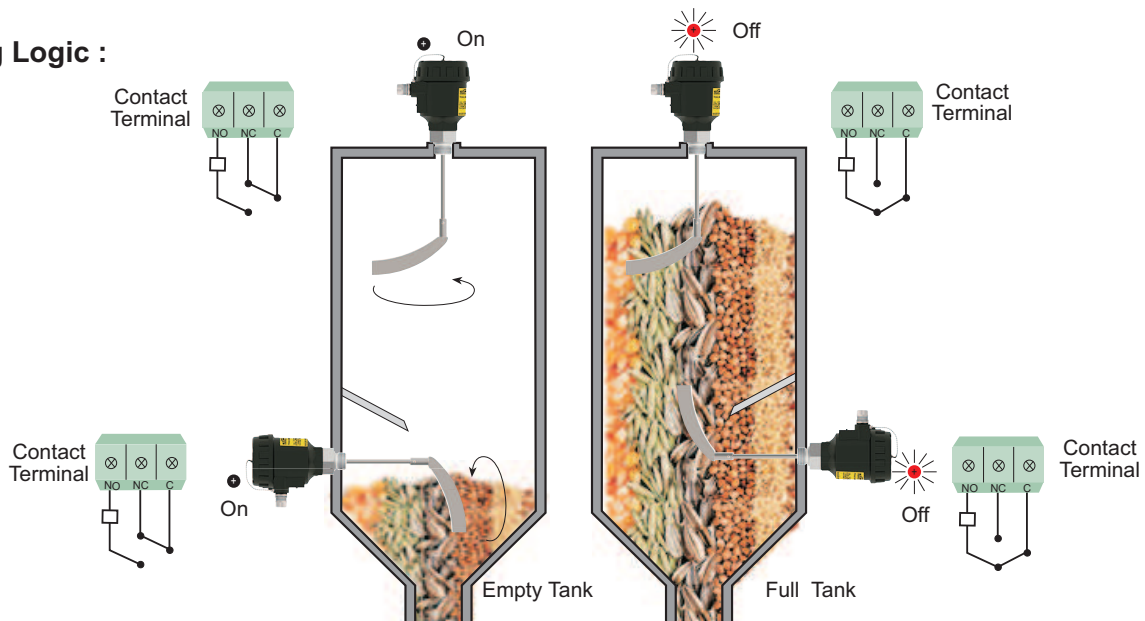

Working Position	Supply	Motor Position	Output Position	Alarm LED Position
Normaly Working	Yes	Stop	-	On light
	Yes	Stop	Full	On light
During an Alarm	Yes	Stop	Full	On light
	No	-	Full	Uninspiring

Torque calibration mechanism :

Torque spring should be used for recalibration of shaft's output torque which is set as low and weak in factory settings. Calibration of torque spring can be adjust to material's weight and density which is specified by customer. If the density of measured material is high, please set the spring to strong position until to get optimal working conditions. High torque setting must be chosen in materials that has adhesion tendency and moist properties. Low torque setting must be chosen for materials that has low density and dry properties.

Sample Models :

DX-ELF 101

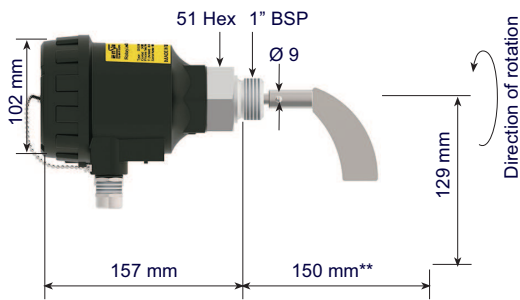

90 °C Opt. 150 °C
Vertical / Horizontal Mounting
Weight 2,1 kg

**DX-ELF 103p
For EPS-XPS**

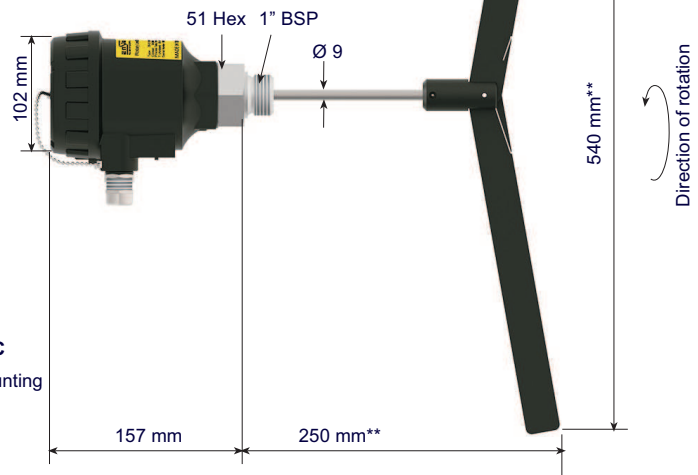

(-20) °C ... (+) 60 °C
Vertical / Horizontal Mounting
Weight 2,2 kg

DX-ELF 102

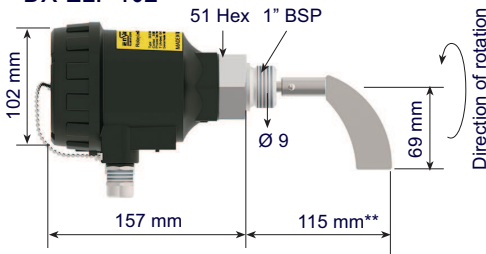

90 °C Opt. 150 °C
Vertical / Horizontal Mounting
Weight 2,1 kg

DX-ELF 103

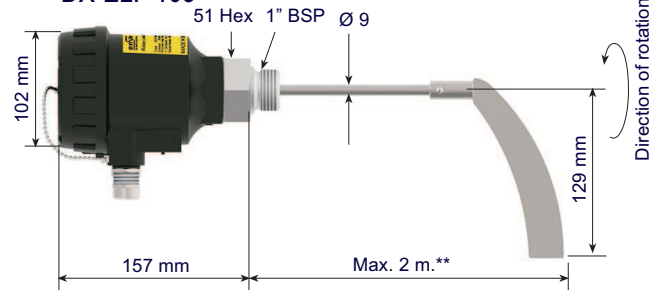

90 °C Opt. 150 °C
Vertical Mounting
Weight 2,2 kg

DX-ELF 104

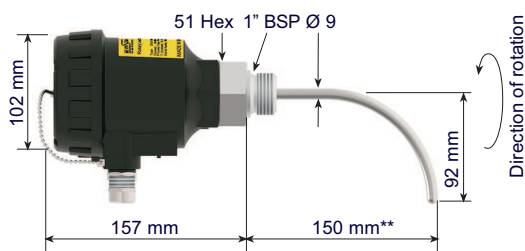

90 °C Opt. 150 °C
Vertical / Horizontal Mounting
Weight 2,1 kg

DX-ELF 105

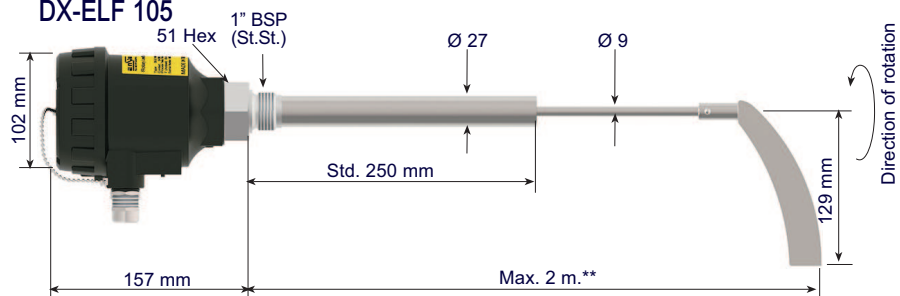

90 °C Opt. 150 °C
Vertical / Horizontal Mounting
Weight 2,6 kg

** Tolerance ± 5 mm .

Sample Models :

DX-ELF 106m

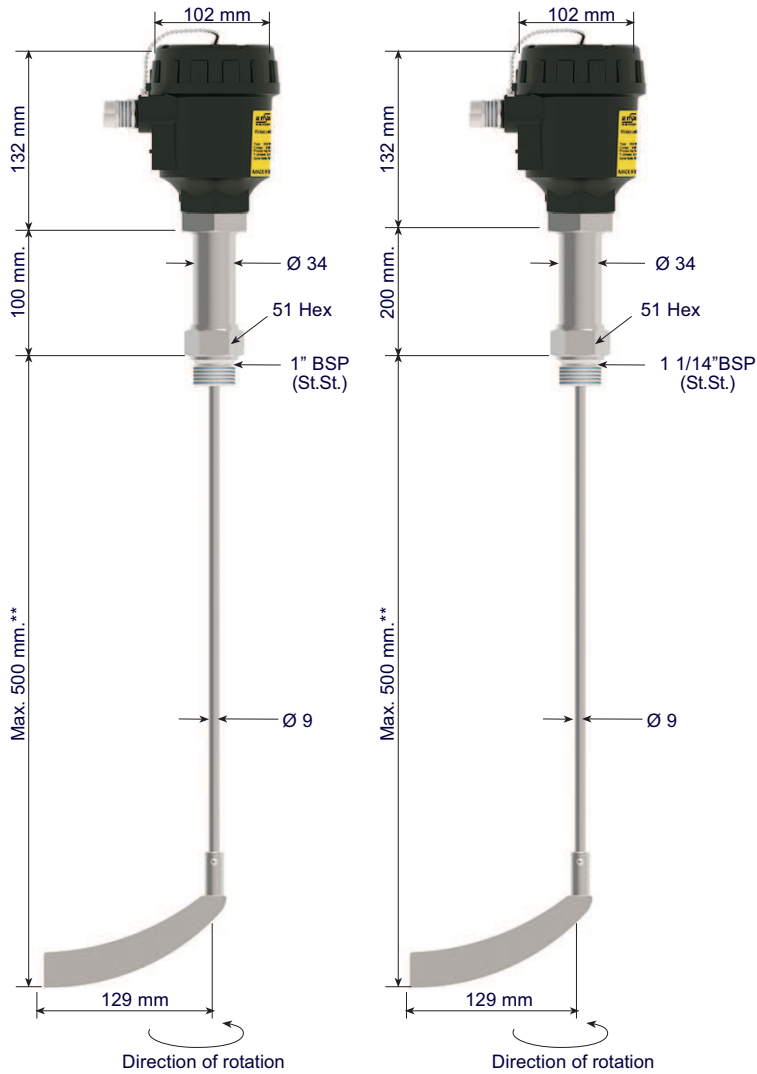

150 °C

Vertical / Horizontal Mounting
Weight 2,4 kg

Opt. 200 °C

Vertical / Horizontal Mounting
Weight 2,4 kg

DX-ELF 106

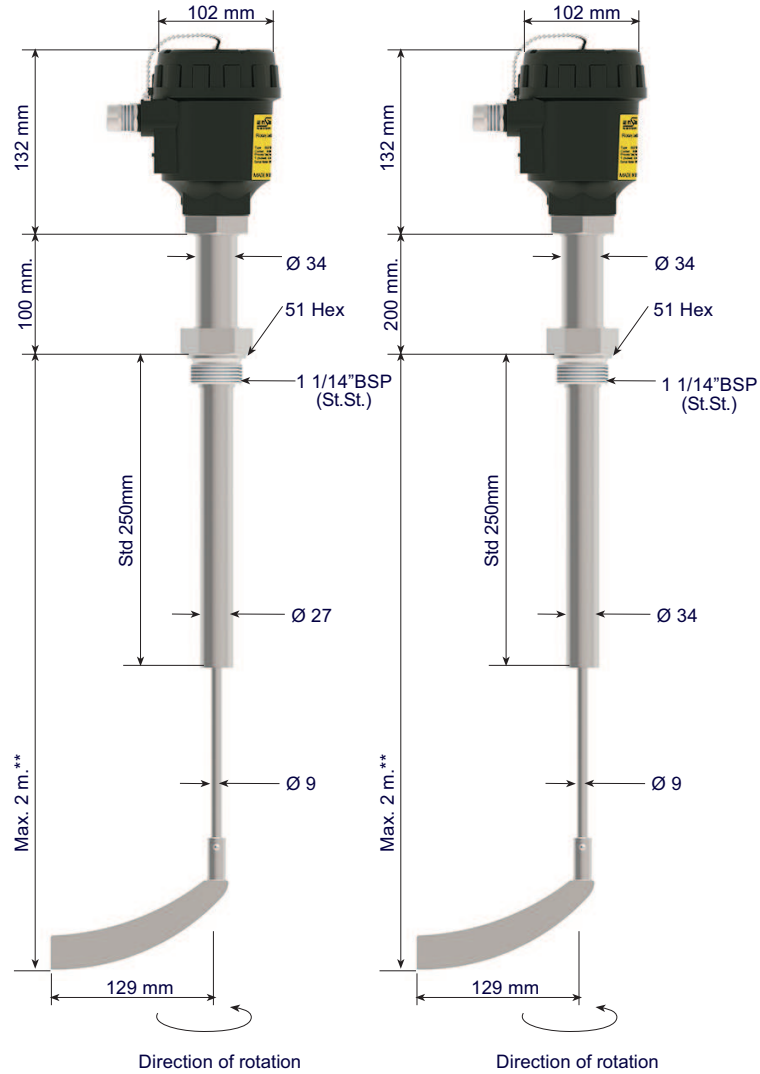

150 °C

Vertical / Horizontal Mounting
Weight 2,8 kg

Opt. 200 °C

Vertical / Horizontal Mounting
Weight 2,8 kg

** Tolerance +/- 5 mm .

Sample Models :

DX-ELF 108

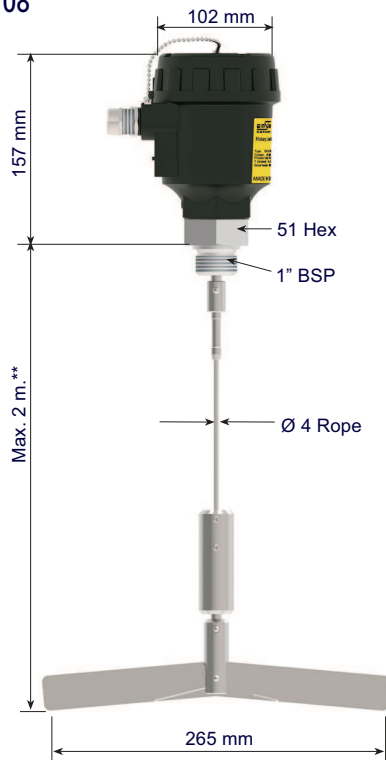

Direction of rotation
90 °C (Opt.150 °C)
 Vertical Mounting
 Weight : 2,7 kg

DX-ELF 109

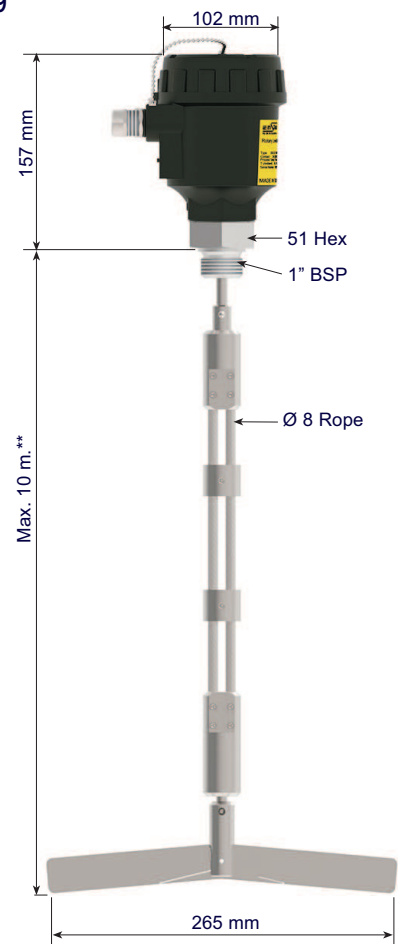

Direction of rotation
90 °C (Opt. 150 °C)
 Vertical Mounting
 Weight : 3,4 kg

** Tolerance ± 5 mm .

Temperature Class Table

STD. MODEL	DX-ELF 101 DX-ELF 102	DX-ELF 103	DX-ELF 104 DX-ELF 105	DX-ELF 108 DX-ELF 109	DX-ELF 103p	DX-ELF 106 DX-ELF 106m
Working temperature	(-) 20 °C...(+) 90 °C				(-) 20 °C...(+) 60 °C	(-) 20 °C...(+) 150 °C
Without opening the cover standby time	20 min.				5 min..	30 min.

Thermal Protection Insurance is 105 °C

(-) 20 °C ≤ T Ambient ≤ (+) 30 °C...(+) 60 °C		Working Temperature : (-) 20 °C...(+) 90 °C			
DX-ELF 101 - DX-ELF 102 - DX-ELF 103 - DX-ELF 104 - DX-ELF 105 - DX-ELF 108 - DX-ELF 109					
T Ambient MAX. AMBIENT TEMPERATURE ZONE 21 / 1	T Process MAX. PROCESS TEMPERATURE ZONE 20 / 0	T Surface MAX. SURFACE TEMPERATURE		TEMPERATURE CLASS	
30 °C	90 °C	58 °C		T6	
40 °C	90 °C	65 °C		T6	
50 °C	90 °C	78 °C		T6	
60 °C	90 °C	88 °C		T5	

(-) 20 °C ≤ T Ambient ≤ (+) 30 °C...(+) 60 °C		Working Temperature : (-) 20 °C...(+) 60 °C			
DX-ELF 103p					
T Ambient MAX. AMBIENT TEMPERATURE ZONE 21 / 1	T Process MAX. PROCESS TEMPERATURE ZONE 20 / 0	T Surface MAX. SURFACE TEMPERATURE		TEMPERATURE CLASS	
30 °C	60 °C	51 °C		T6	
40 °C	60 °C	59 °C		T6	
50 °C	60 °C	74 °C		T6	
60 °C	60 °C	86 °C		T5	

(-) 20 °C ≤ T Ambient ≤ (+) 30 °C...(+) 60 °C		Working Temperature : (-) 20 °C...(+) 150 °C			
DX-ELF 101 - DX-ELF 102 - DX-ELF 103 - DX-ELF 104 - DX-ELF 105 - DX-ELF 106 - DX-ELF 106m - DX-ELF 108 - DX-ELF 109					
T Ambient MAX. AMBIENT TEMPERATURE ZONE 21 / 1	T Process MAX. PROCESS TEMPERATURE ZONE 20 / 0	T Surface MAX. SURFACE TEMPERATURE		TEMPERATURE CLASS	
30 °C	150 °C	65 °C		T6	
40 °C	150 °C	70 °C		T6	
50 °C	150 °C	82 °C		T6	
60 °C	150 °C	91 °C		T5	

(-) 20 °C ≤ T Ambient ≤ (+) 30 °C...(+) 60 °C		Working Temperature : (-) 20 °C...(+) 200 °C			
DX-ELF 106 - DX-ELF 106m					
T Ambient MAX. AMBIENT TEMPERATURE ZONE 21 / 1	T Process MAX. PROCESS TEMPERATURE ZONE 20 / 0	T Surface MAX. SURFACE TEMPERATURE		TEMPERATURE CLASS	
30 °C	200 °C	50 °C		T6	
40 °C	200 °C	54 °C		T6	
50 °C	200 °C	64 °C		T6	
60 °C	200 °C	80 °C		T5	

Paddle Shapes:

Standard Scimitar Paddle
(258 mm)

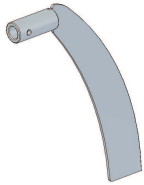

Weigh 105 g.

Paddle 1 (304 St.St.)
Paddle 2 (316 St.St.)

Mini Scimitar Paddle
(138 mm)

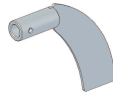

Weigh 75 g.

Paddle 3 (304 St.St.)
Paddle 4 (316 St.St.)

Double-Baded Collapsible Paddle
(265 mm)

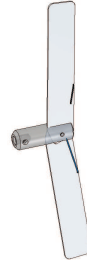

Weigh 235 g.

Paddle 5 (304 St.St.)
Paddle 6 (316 St.St.)

Double-Baded Collapsible Paddle
(540 mm)



Weigh 120 g.

Paddle 11 (Plexiglass)

Cross-Wing Paddle
(105x90 mm)

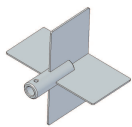

Weigh 185 g.

Paddle 9 (304 St.St.)
Paddle 10 (316 St.St.)

Cross-Wing Paddle
(148x98 mm)

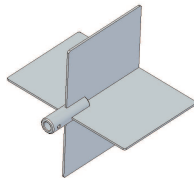

Weigh 515 g.

Paddle 7 (304 St.St.)
Paddle 8 (316 St.St.)

Single Wing Paddle
(75x35 mm)

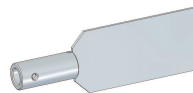

Paddle 12 (304 St.St.)
Paddle 13 (316 St.St.)

Single Wing Paddle
(80x65 mm)

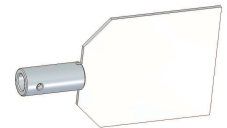

Paddle 14 (304 St.St.)
Paddle 15 (316 St.St.)

Density of examples that can be applicable :

Material	Min.Density (Kg/m ³)	Material	Min.Density (Kg/m ³)
Chopped Corn	550	Metals, Iron Chips	2650
Crushed limestone	1350-1510	Coal Pellet	400-800
Sawdust	50-160	Dry Malt Floor	310
Rubber Floor	400-800	Dry Coarse Coal	560-725
Tea Leaves	195	Grain - Oat	400-560
Shelled Peanut	550-710	Sugary Granule	880
Dusting Powder	730-990	Wheat	400-500
Acrylic Resin	330	Breadstuff	600-800
Wheat flour	480-560	Aquaous Lime Powder	400-500
Cement Dust	1370-1510	Powder PVC	300-600
Silica Sand	1510	Granule PVC	300-600
Lumpy Polypropylene	540-575	Sunflower Marsh	300-500
Roasted Coffee	350-480	Red Pepper	800-1000

Accessories :

You can consult our company for ex-proof models.

Reduction :

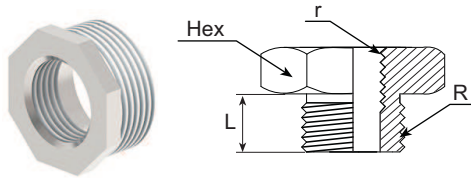

Order Code	R	r	L mm	Hex	Material
/ R1	1" BSP	1 1/4" BSP	21	44	304 St.St.
/ R2	1" BSP	1 1/2" BSP	19	50	304 St.St.
/ R7	1" BSP	2" BSP	25	60	304 St.St.
/ R3	1" BSP	1 1/4" BSP	21	44	316 St.St.
/ R4	1" BSP	1 1/2" BSP	19	50	316 St.St.
/ R5	1" BSP	1 1/4" BSP	22	45	ST 37 Steel
/ R6	1" BSP	1 1/2" BSP	22,5	50	ST 37 Steel

Muff :

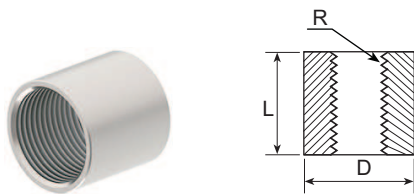

Order Code	R	D mm	L mm	Material
/ M1	1" BSP	Ø 37	41	304 St.St.
/ M2	1 1/4" BSP	Ø 47,5	46,5	304 St.St.
/ M3	1 1/2" BSP	Ø 54,4	48,1	304 St.St.
/ M4	1" BSP	Ø 37	41	316 St.St.
/ M5	1 1/4" BSP	Ø 47,5	46,5	316 St.St.
/ M6	2" BSP	Ø 54,4	48,1	316 St.St.
/ M7	1" BSP	Ø 37,6	40,2	ST 37 Steel
/ M8	1 1/4" BSP	Ø 47,8	47	ST 37 Steel
/ M9	1 1/2" BSP	Ø 52,6	46,5	ST 37 Steel

Flange :

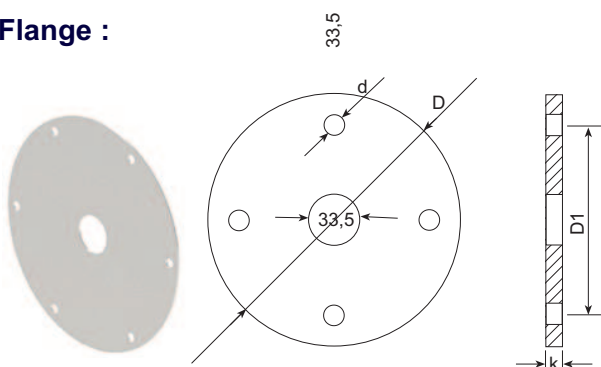

Order Code	D	D1	d	k	Number of Hole	Material
/ F1	110	90	8	2	4	304 St.St.
/ F2	110	90	8	2	4	316 St.St.
/ F3	200	180	8	2	6	304 St.St.
/ F4	200	180	8	2	6	316 St.St.

Note : 1" BSP With 1" Nut-Aluminium

Protection Case:

Material : 304 St. St.
 Welded Production
 Open - Close hinged
 For Protection of switch from external conditions

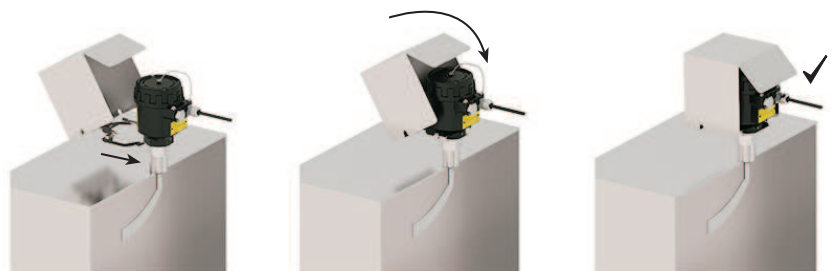

Order Form : Please consider sample models when coding

1 MODEL DX-ELF

Standart.....1

2 CERTIFICATE

None.....0 (EN10204-3-1) Material Certification.....1

3 SHAFT TYPE - (STEM LENGHT)

Standart Shaft - L= 150 mm.....1	Shaft With Extention Tube - L= 2m.(For High Temperature).....6
Mini Shaft - L= 75 mm.....2	Mini-Shaft With Extention Tube - L= 150mm Max.500.....6m
Long Shaft - L= 500 mm3	Rope Shaft - L= 2000 mm).....8
Standart Shaft - L= 250 mm.....3p	Reinforced Rope (28 KN) - L= Max.10 m.....9
Single Shaft - L= 500 mm4	Special.....x
Cable Extented Shaft - L= 500 mm.....5	

4 PADDLE TYPE

Without Paddle (184 mm)0	Cross-Wing Paddle (210 mm).....5
Standart Scimater Paddle (258 mm).....1	Cross-Wing Paddle (298 mm).....6
Mini Paddle (138 mm).....2	Single Wing Paddle (80x65 mm).....7
Double-Baded Collapsible Paddle (265 mm).....3	Single Wing Paddle (74x35 mm).....8
Double-Baded Collapsible Paddle-Plexiglass(540 mm).....4	Special.....x

5 CONNECTION

* 1" BSP Male Thread (Std).....006	1 1/2" BSP Male Thread008
1 1/4" BSP Male Thread007	Special.....x

***Those can be choosen(applicable)only products with 90 Celcius working temprature.**

6 CONNECTION MATERIAL

304 Stainless Steel.....01	Special.....x
316 Stainless Steel.....02	
Aluminium (Std).....31	

7 POWER SUPPLY

24 VDC.....1	220 VAC 50/60 Hz ± %10.....4
24 VAC 50/60 Hz ± %102	48 VAC 50/60 Hz ± %10.....5
110 VAC 50/60 Hz ± %10.....3	Special.....x

8 REVOLUTIONS PER MINUTE

5 rpm (Std)1	Special.....x
1,5 rpm2	

9 MATERIAL OF POWDER FEELTING

PTFE Max. 200 °C.....66	Special.....x
NBR (Std) Max.90 °C.....81	
FPM Maxs. 150 °C.....85	

10 ROLLER

Metal Ball Bearing (Std) 120 °C.....1	Metal Ball Bearing 280 °C.....3
Ceramic Ball Bearing.....2	Special.....x

11 HOUSING MATERIALS

Aluminum B20x.....368	Special.....x
-----------------------	---------------

12 ELECTRICAL CONNECTION

With Terminal.....00	Special.....x
----------------------	---------------

13 OPTIONAL

None...../ 0	Muff 1" BSP 304 St.St...../ M1
Reduction 1" BSP - 1 1/4" BSP 304 St.St...../ R1	Muff 1 1/4" BSP 304 St.St...../ M2
Reduction 1" BSP - 1 1/2" BSP 304 St.St...../ R2	Muff 1 1/2" BSP 304 St.St...../ M3
Reduction 1" BSP - 1 1/4" BSP 316 St.St...../ R3	Muff 1" BSP 316 St.St...../ M4
Reduction 1" BSP - 1 1/2" BSP 316 St.St...../ R4	Muff 1 1/4" BSP 316 St.St...../ M5
Reduction 1" BSP - 1 1/4" BSP ST 37 Steel...../ R5	Muff 1 1/2" BSP 316 St.St...../ M6
Reduction 1" BSP - 1 1/2" BSP ST 37 Steel...../ R6	Muff 1" St 37 Steel...../ M7
Reduction 1" BSP - 2" BSP 304 St.St...../ R7	Muff 1 1/4" ST 37 Steel...../ M8
Flange with muff 110 mm 304 St.St...../ F1	Muff 1 1/2" ST 37 Steel...../ M9
Flange with muff 110 mm 316 St.St...../ F2	M12 x 5 pin socket (Max. 60 V)...../ S1
Flange with muff 200 mm 304 St.St...../ F3	External LED socket...../ L1
Flange with muff 200 mm 316 St.St...../ F4	Change for body - Cover/ Z1
Protection plate 304 St.St...../ K1	Special.....x
Shelter - (For the outside of the tank) 304 St.St. / K2	

Important Note : In high temperature applications , felting and protection material must be selected appropriately.

SAMPLE

DX-ELF 101 - 1 - 006 - 31 - 1 - 1 - 81 - 1 - 368 - 00 / 0

Rotary Level Switch , DX-ELF 101 , Standard Paddle , L=150 mm , 1" BSP, 24VDC