

OPERATING MANUEL

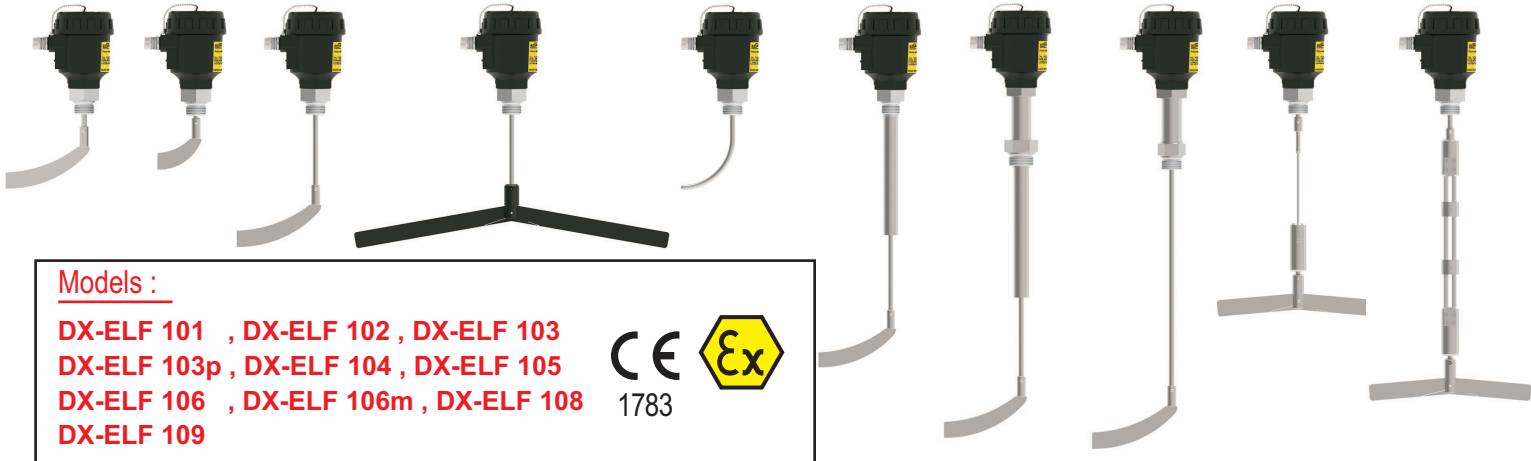

Model : **DX-ELF**
ROTARY LEVEL SWITCH



Information in this manual is reviewed and completely reliable. Responsibility is not assumed due to any typing error. Products in this manual are available only for information purpose and they may be changed without notice.



Models :
DX-ELF 101 , DX-ELF 102 , DX-ELF 103
DX-ELF 103p , DX-ELF 104 , DX-ELF 105
DX-ELF 106 , DX-ELF 106m , DX-ELF 108
DX-ELF 109











1783

Important Notes:

Used Symbols :

-  : Caution
-  : Note
-  : Disposal

-  Please read this manual carefully before installation of the level switch. User is responsible for accidents and losses arising from failure to comply with the warnings in this manual.
-  In the event that level switch is broken, take measures in order to prevent accidents and losses which can occur in its system.
-  This manual should be stored in an easily accessible place for subsequent use.
-  Do not operate the system before making assembly in compliance with the assembly chart related to the instrument.
-  Manufacturer's liability may not be higher than the purchasing amount of the device pursuant to the local laws.
-  Do not make any modification on the instrument and do not try to repair it. Reparation should be made by authorized service personnel.
-  Products which do not contain label and serial number are considered to be excluded from the warranty scope.

Contents :

1. General Information.....	2
2. Installation	6
3. Failure Detection.....	19
4. Disassembly of Instrument	19
5. Service	19
6. Recalibration.....	19
7. Repair.....	19
8. Disposal.....	19
9. Terms of Warranty	19
10. Terms of Return	19

1. General Information :

1.1. Material Acceptance

Check that there is no damage on the packages during the transportation immediately after the material acceptance. If packages are damaged, open the packages immediately and check whether products are affected or not, if there is any damage, send your complaint report to the transporter company and its photocopy to the address of our company.

1.2. Information about Areas of Use

Level Switch is designed for industrial facilities. It must not be used in mines. If its used in mines, responsibility of manufacturer will be abolished.

Plastic Industry ; PVC, PVDF, PP granular etc..

Food Industry ; Grain Dust, Ground Corn, Sugar-Granulated, Cacao, Malt-Graoung Dry, Sunflower Corn, Whead, Peanuts-Shelled, Clays- Kaoline, Talcum Powder, Ground-Paprika, Coffee-Roasted vb..

Build Industry ; Rocks-Limestone Crushed, Lime, Cement Powder, Rubber Ground, Lime Hydrate Dust, Calsium Dust, Iron Chips, Silica Sand, Moulding Sand, Styrofaam etc..

Wood Industry ; Wooden Fiberst, Saw Dust etc..

Other Chemistry Industry ; Coal Lump, Ash-Coal Dry etc..

Advantages

- * Fast delivery period
- * Reverse-rotation safety
- * Adjustable precision
- * Perfect mechanical durability

Ambient Conditions : Relative Humidity: 0-95 %RH Ambient Temperature: 60C (It is not used under -20 C)

1.3. Working Principle

A palette selected according to the material is installed on the tip of the motorized level switch which can be installed on the tank wall. It revolves idly with the revolution speed of the probe motor. Material to be detected reaches to the level of the palette and covers its circumference and creates a counter-force according to the revolution force. Firstly, level information alarm contact is activated. Then, the other contact is triggered and stops the motor. Adjustment of the spring in four different torque values according to specific weight of the material can be realized by the user. When the material level at the end of the palette is decreased the created force is released and the motor starts to revolve, consequently, changing the alarm position.

Certification

For Dust II 1/2D Ex ta/tb IIIC T°C IP66

For Gas II 1/2G Ex d IIC T°C IP66

*Loot at temperature class table

1.4. Technical Specifications and Material Information

Working Temperature (Tp)	(-) 20(+) 90°C , (-) 20(+) 60°C (With plastic connection type) Opt. Max.150°C With High Temperature Type , Max.200°C With High Temperature Type
Ambient Humidity	0-98 %Rh (Non Condensate)
Ambient Temperature (Ta)	(-) 20 ... (+) 60°C
Working Pressure	(-) 0,6 ... (+) 0,6 bar
Malzeme Connection Housing	Aluminium , Opt. 304 / 316 Stainless Steel, PTFE, PVC, Delrin Aluminium Injection - AISI12Fe (Std) Black (RAL:9005)
Paddle And Rode	304 Stainless Steel (Std) Opt. 316 Stainless Steel
Extension Pipe	304 Stainless Steel (Std) Opt. 316 Stainless Steel
Grounding Apparatus	304 Stainless Steel
O-Ring for Cover	Elastomer Thermoplastic 120°C (Std) Opt. FPM (Viton) 150°C
Bearing	Double ball bearing (With Dust-protected) (120°C) Opt. 280°C
Dust Protected Felting	NBR (Std) Opt. FPM (Viton) 150°C, PTFE 200°C
Connection	1" BSP (Std) , Opt. 1 ¼" BSP , 1 1/2" BSP Male Thread
Power Consumption	Max. 4W
Revolutions Per Minute	5 d/d (Std) (Clockwise - When Looking Paddle Side) Opt. 1,5-1,8 d/d
Power Supply	24 VDC +/- %10 , 24/48/110/220 VAC 50/60 Hz +/- %10
Cable and Stopper Input	M20x1,5 (Std)
Relay Switching Capacity	10A/250 VAC - 4A/30VDC 2xNONC (SPDT) 5E4
LED	Power LED: Green , Alarm LED: Red
Max. Grain Structure	50mm
Min. Density	0,04 g/cm3 (According to paddle type)
Torque Rating	4 Stages, adjustable
Load on Probe	Max. 500 N (Extention Pipe)
Protection Class	IP 66 (EN60529)
Certification and Approvals	CE Declaration , EMC , LVD , ATEX

1.5. Label Information :

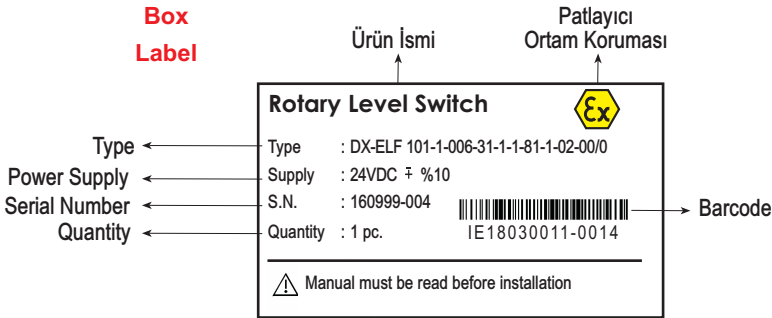
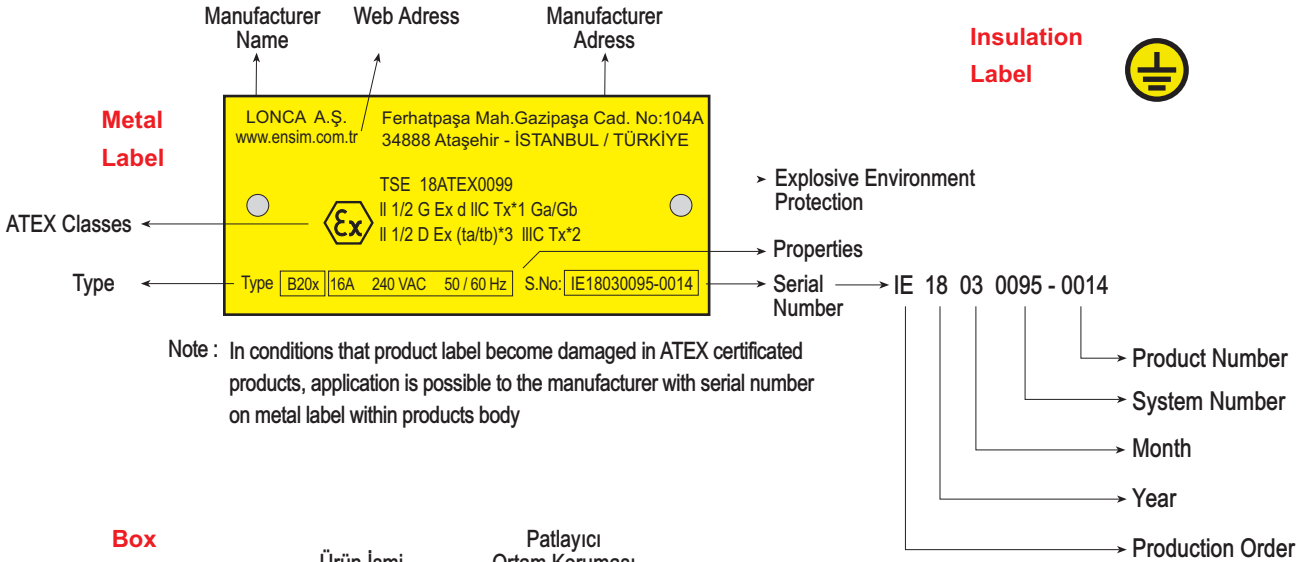
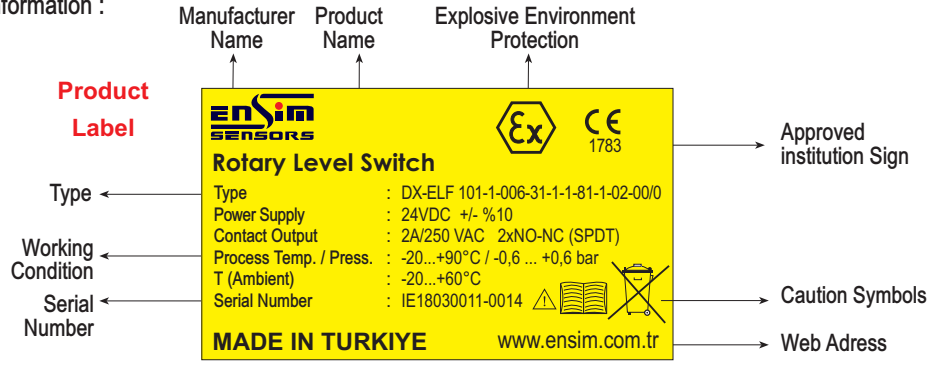

1.6. Package and package contents :

Please check whether you have taken delivery of below listed content completely or not and check its conformity with criterions in your order:

- *Rotary Level switch
- *This operating manual



260 x 160 x 125 mm
Std.Kutu

1.7. Target Group

This operating manual has been prepared for qualified technical staff

1.8. Certifications and Approvals

CE	:	It shows that, product meets required conditions of EU with CE stamp and stipulate that product passed quality assessment stages
ATEX (2014 / 34 / AB)	:	TS EN 60079 - 0 : 2013 TS EN 60079 - 1 : 2014 TS EN 60079 - 31 : 2014
LVD (2014 / 35 / AB)	:	TS EN 61010 - 1 : 2012 TS 3033 EN 60529 : 1397
EMC (2014 / 108 / AT)	:	TS EN 61326 - 1 : 2013

Note : LONCA A.Ş. , who is the manufacturer company, applied all features and test, that stated in this document, to the all products, that produced as DX-ELF model.

1.9. Safety Instructions (ATEX)



All safety instructions must be read and fulfilled.

- All notes below must be paid attention to avoid dangers that might occur near operator and his environment.
- Installation of this device , usage and service must be done by people who read manual and have knowledge about work safety.
- Products must be controlled, if its mounted properly according to zone map of products by user
- Work safety, accident prevention regulations and universal installation standards must be complied.
- Product must be used only within stated specifications.
- Device can be mounted only when there is no pressure.
- This safety instructions are only for products that coded as DX-ELF and protected from in terms of explosion threat, categorized in 1/2 D and 1/2 G.

It is compatible with TSE 18ATEX0099 and CE certificate

- It must be used compatible in order to properties on label.
- Because of environment temperature can be maximum 80°C , cable must be choosen compatible.
- In order to not affect IP protection class , do not tighten cable socket excessively (Max: 5Nm)
- Ensure that cable input and plug tighten correctly
- Ground connection must be done correctly and controlled before energized.
- Before energized and using the product, cover and setskur screw must be controlled that tighten enough
- DX-ELF models have metal casings and those are compatible with engines that have different supply and voltage shown in catalogue
- Metal casing must be inside 2D or 2G zone. Rode and paddle part must be inside 1D or 1G zone
- Maximum working temperature and maximum surface temperature are variable in order to product model.

Documents must be read carefully before usage.

- Mechanical tension and deformations on tanks surface must be checked in assembly process.

When, a situation occurs like that, sensor must not be energized before taking necessary precautions

- The pressure inside the tank must be controlled that not above from working pressure stated in catalogue
- Assembly of sensor must be compatible with tank loading system. In conditions that are not compatible , inside the tank must be protected with protection apparatuses
- The sensor has designed as to withstand materials chemical affects that in proper environmental conditions which is stated in this manual.

Other materials compatibility must be controlled.

- Sensor must be protected against moisture and dust in proper storage conditions.
- Repairs of device must be done only in LONCA A.Ş which is manufacturer company.
- Device must be protected against friction and cleaning must be done without water.
- In an inappropriate circuit condition, before replacing the temperature circuit breaker with its backup , main power must be turned off completely and safety precautions must be taken. Changing must be done in a safe area.

1.10. ATEX Symbols Explanations

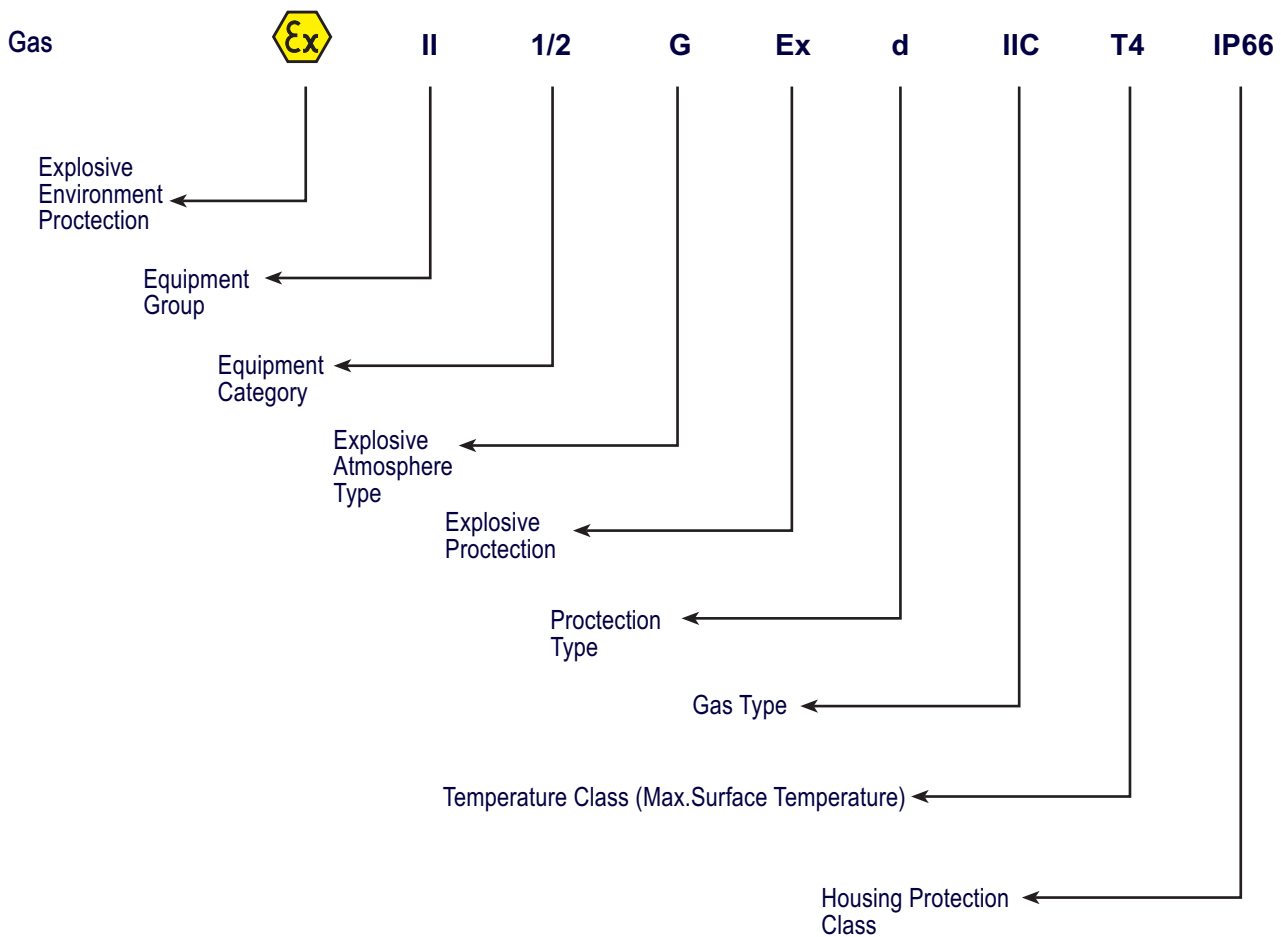
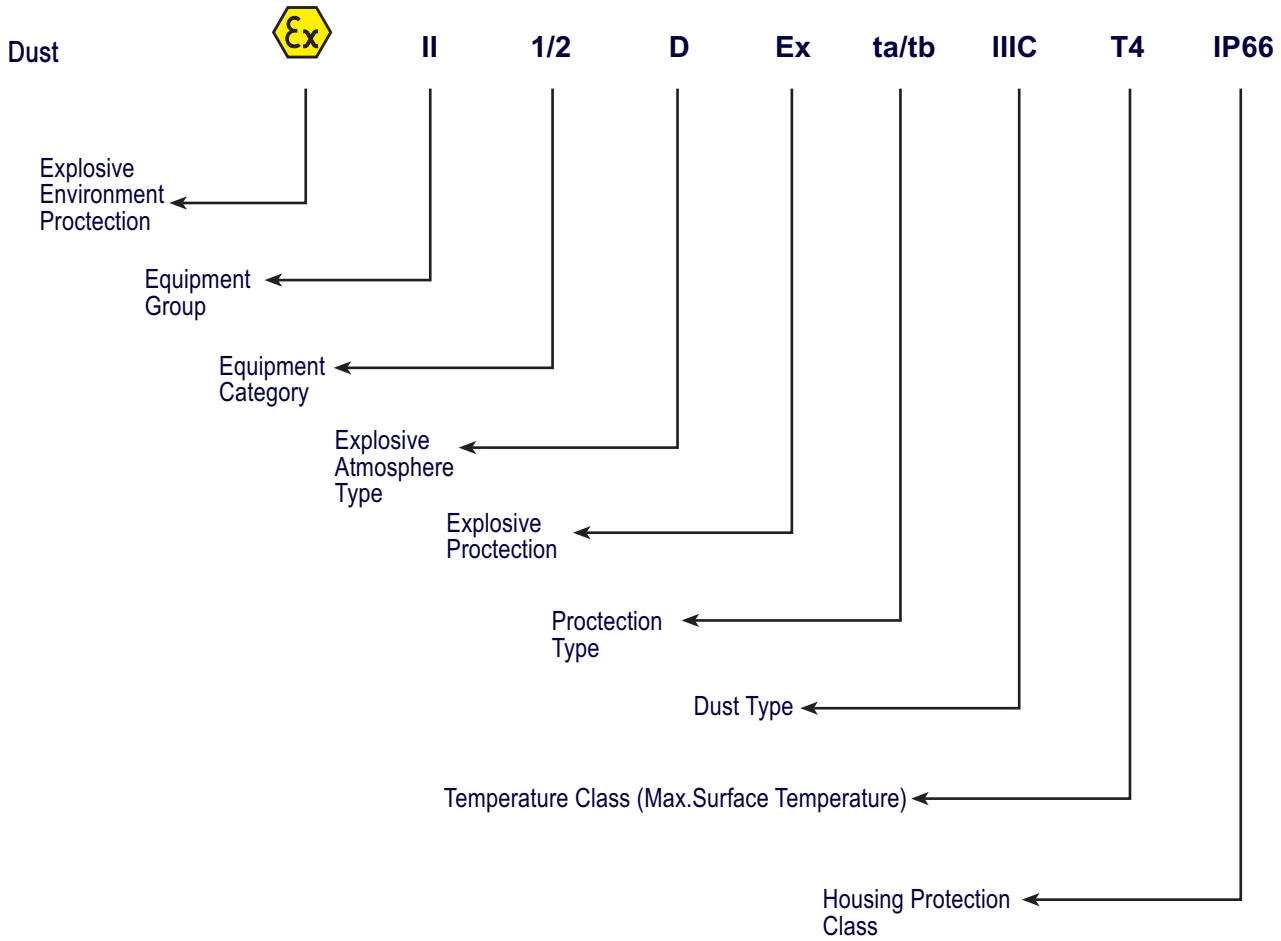

2. Installation :

2.1. General Notes

Installation of device must be done by only authorized staff, that has known about 2014/34/EU criterias, for ensuring safety against explosion and liable against preventing harms to third party
Installation of the instrument should be made only by authorized staff.
Do not apply force to the instrument during the installation!
Do not use the level switch with a greater pressure than recommended pressure.
Do not forget that instrument is precise, carry it carefully and prevent to be damaged.
It should be guaranteed that there are not any magnetic particles.
Max. Working Pressure must not be exceeded.

2.2. General Installation Stages

*Remove level switch from the box carefully
*Check whether gasket is appropriate for fluid or not. If is not appropriate, contact with the manufacturer.
*Then, apply below mentioned explanations according to structure of the design.

2.3. Special Notes

*Please ensure that there is no mechanical stress on the shaft following installation.
Such case will cause slipping in the characteristic curve.
*Level switch should be placed in completely vertical or horizontal position to the tank.
*Allocate valve certainly in the process connection while instrument is used.
*Allocate blowdown valve under bottom flange for blowdown.
*If instrument is mounted outside and if there is any danger of lightning or excessive pressure, please take precawtions to prevent any harm.
*In the operating conditions, level switch may be hot according to situation of fluid, in this case, do not touch the switch, otherwise your skin can be harmed.
*Insulation of product must be done properly (It can be done externally or inside the housing.)

2.4. Installation For Mechanical Connections

*Use appropriate O-Ring or gasket for tightness.
*Ensure that its surface is clean and smooth.
*Assemble the instrument manually.
*Connect the contacts as shown in the figure. (Max.20 Nm for G1", Max.30 Nm for G1 1/4" and G1 1/2")

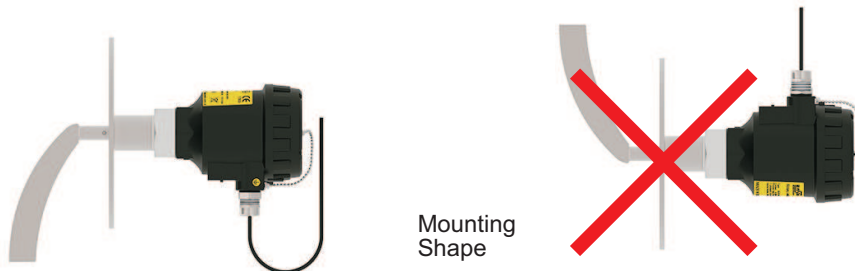

2.5. Example Mounting Types:

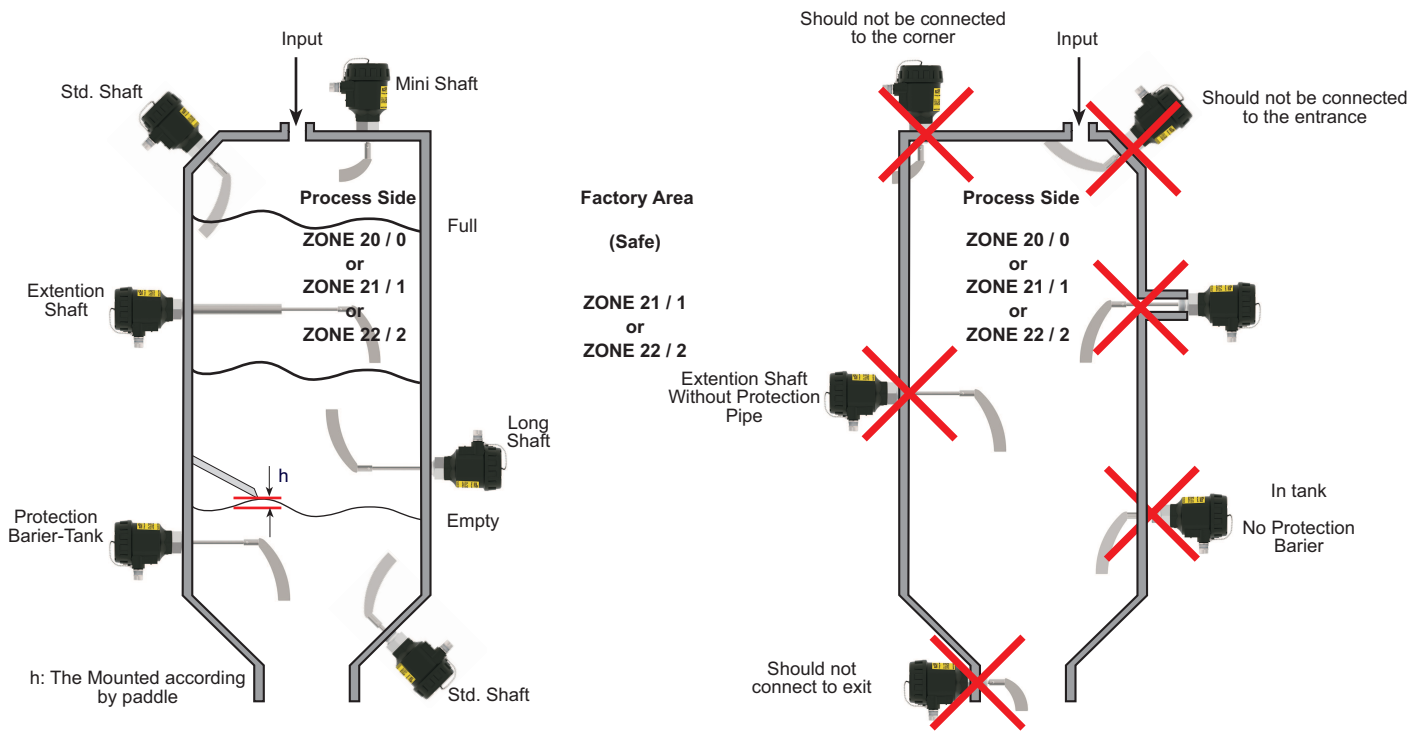

2.6. Switching Logic :

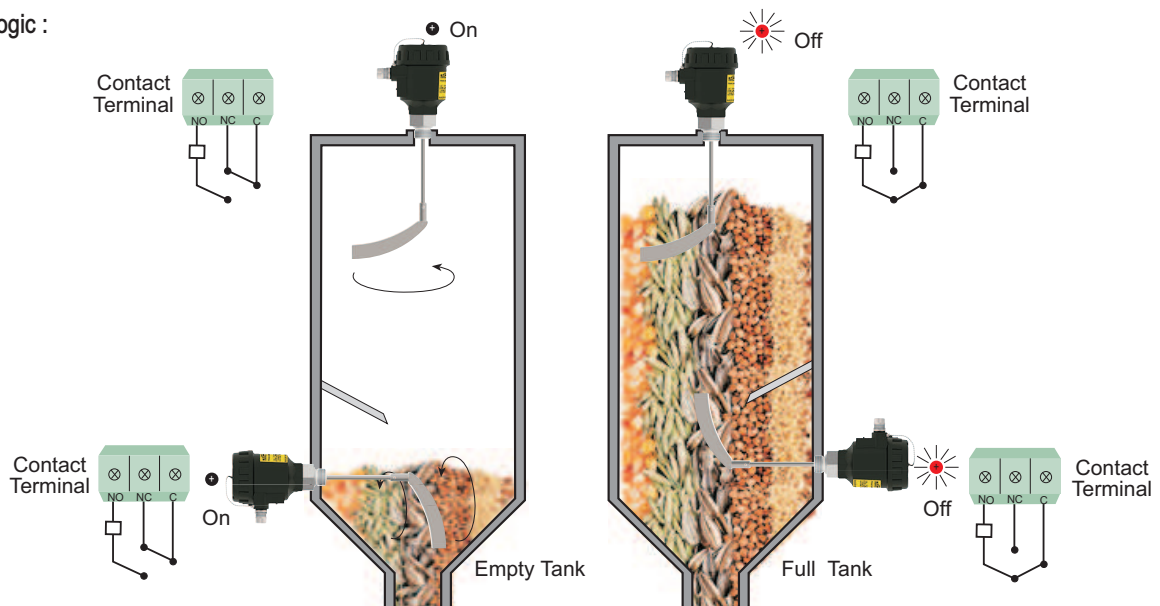

Working Position	Supply	Motor Position	Output Position	Alarm LED Position
Normaly Working	Yes	Stop	-	On light
	Yes	Stop	Full	On light
During an Alarm	Yes	Stop	Full	On light
	Yes	-	Full	Uninspiring

2.5. Torque calibration mechanism :

Torque spring should be used for recalibration of shaft's output torque which is set as low and weak in factory settings. Calibration of torque spring can be adjust to material's weight and density which is specified by customer. If the density of measured material is high, please set the spring to strong position until to get optimal working conditions. High torque setting must be choosen in materials that has adhesion tendency and moist properties. Low torque setting must be choosen for materials that has low density and dry properties

2.7. Electrical Installation

Make the electrical connection of the instrument according to details on its label, table and cable figures in this manual.

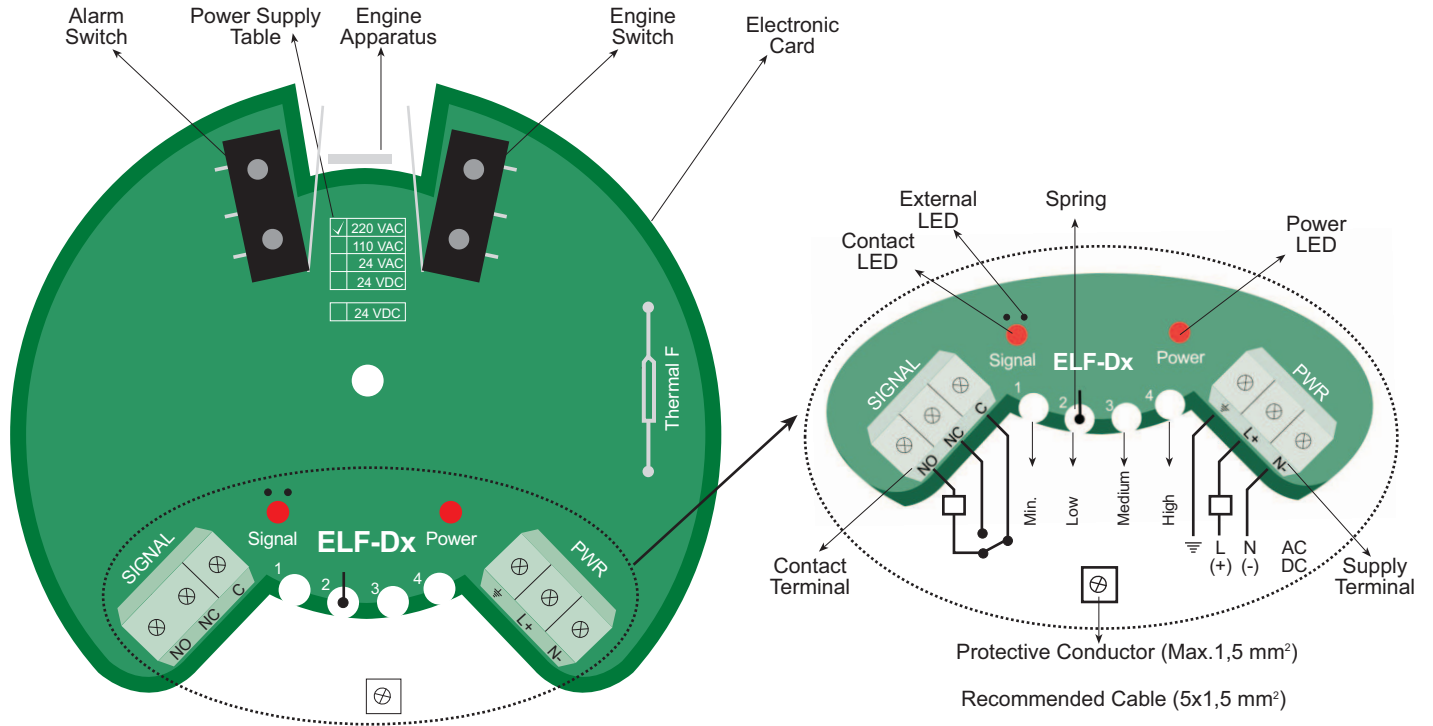

Note : It has been produced according to IPC A 600 class 2 conditions and tested with 100 % E-test. Moreover, HASL (non-lead) surface test has been applied.

2.8. Mecahanical Parts and Connection Apparatus:

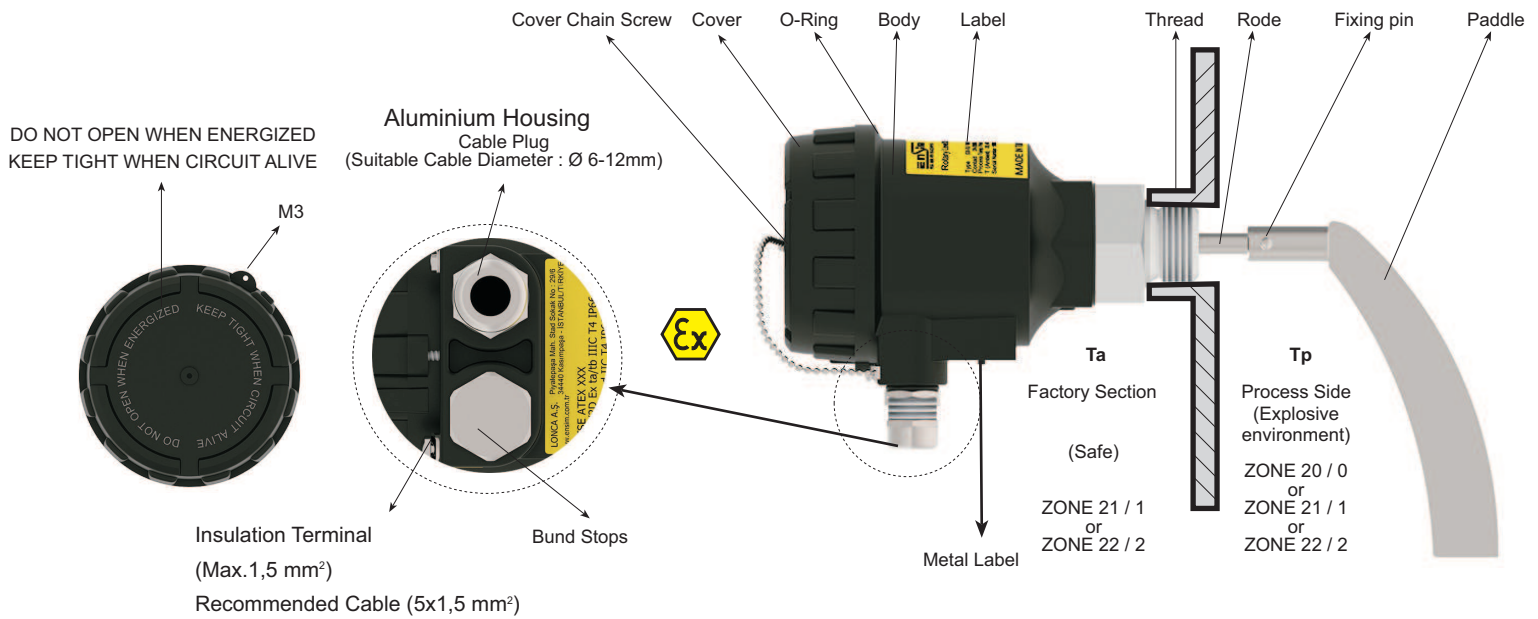

MODULAR STRUCTURE:

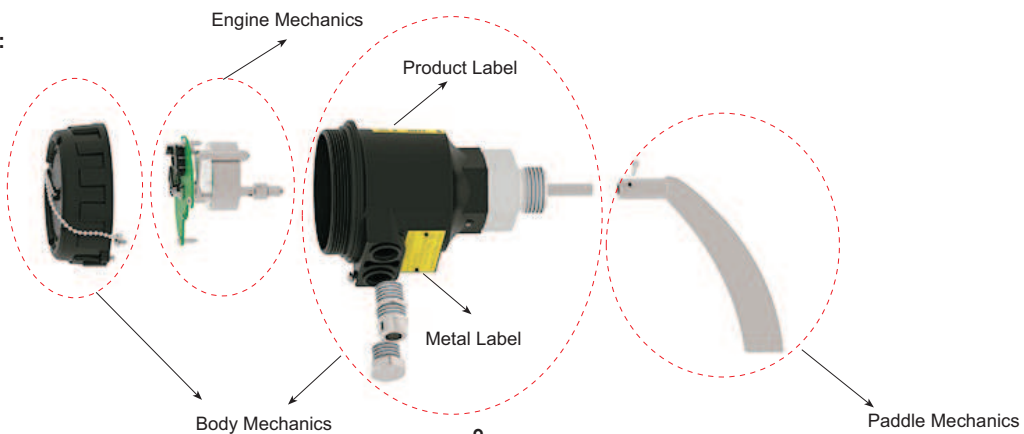

2.9. Connection Accessories :

You can consult our company for the Ex-proof models.

Reduction :

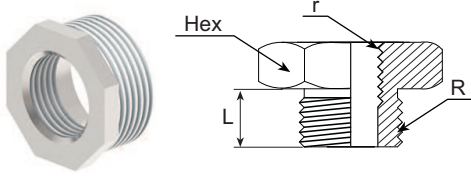

Order Code	R	r	L mm	Hex	Material
/ R1	1"BSP	1 1/4" BSP	21	44	304 St.St.
/ R2	1"BSP	1 1/2" BSP	19	50	304 St.St.
/ R7	1"BSP	2" BSP	25	60	304 St.St.
/ R3	1"BSP	1 1/4" BSP	21	44	316 St.St.
/ R4	1"BSP	1 1/2" BSP	19	50	316 St.St.
/ R5	1"BSP	1 1/4" BSP	22	45	ST 37 Steel
/ R6	1"BSP	1 1/2" BSP	22,5	50	ST 37 Steel

Muff :

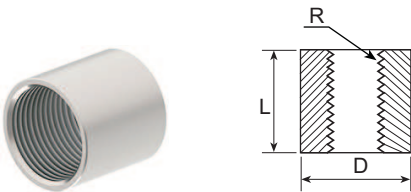

Order Code	R	D mm	L mm	Material
/ M1	1"BSP	Ø 37	41	304 St.St.
/ M2	1 1/4"BSP	Ø 47,5	46,5	304 St.St.
/ M3	1 1/2"BSP	Ø 54,4	48,1	304 St.St.
/ M4	1"BSP	Ø 37	41	316 St.St.
/ M5	1 1/4"BSP	Ø 47,5	46,5	316 St.St.
/ M6	2"BSP	Ø 54,4	48,1	316 St.St.
/ M7	1"BSP	Ø 37,6	40,2	ST 37 Steel
/ M8	1 1/4"BSP	Ø 47,8	47	ST 37 Steel
/ M9	1 1/2"BSP	Ø 52,6	46,5	ST 37 Steel

Flange :

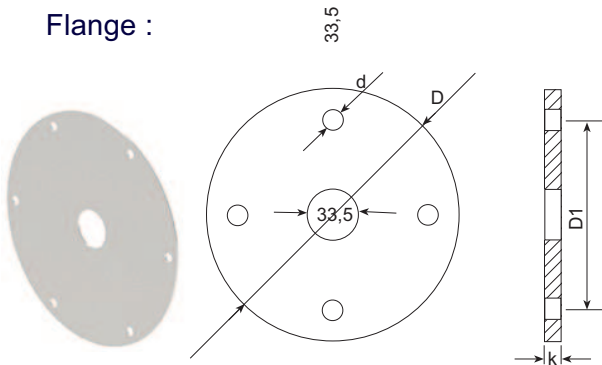

Order Code	D	D1	d	k	Number of Hole	Material
/ F1	110	90	8	2	4	304 St.St.
/ F2	110	90	8	2	4	316 St.St.
/ F3	200	180	8	2	6	304 St.St.
/ F4	200	180	8	2	6	316 St.St.

Note : 1"BSP With 1" Nut-Aluminium

Protection Case:

Material : 304 St. St.
 Welded Production
 Open - Close hinged
 For Protection of switch from external conditions

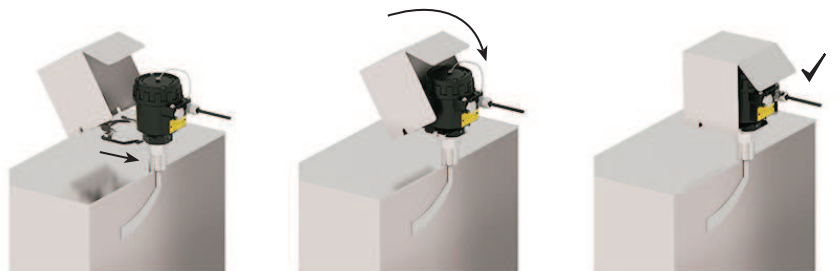

2.10. Sample Models :

DX-ELF 101

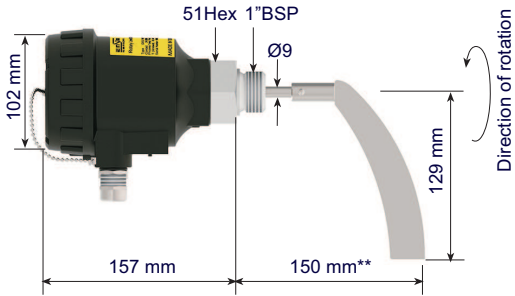

90°C Opt. 150°C
Vertical / Horizontal Mounting
Weight 2,1 kg

**DX-ELF 103p
(For EPS-XPS)**

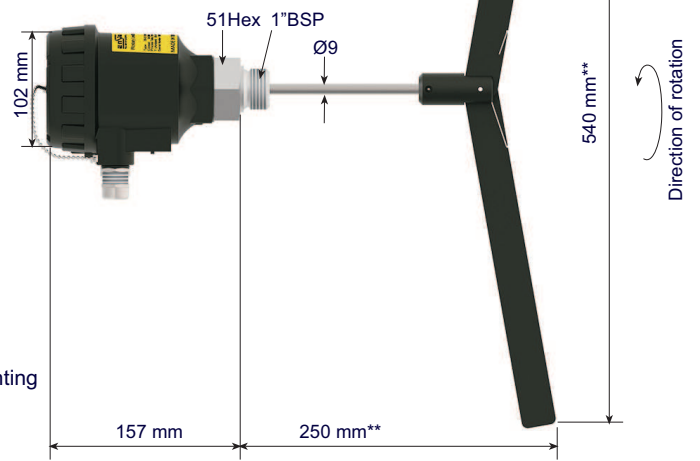

(-20)...+60°C
Vertical / Horizontal Mounting
Weight 2,2 kg

DX-ELF 102

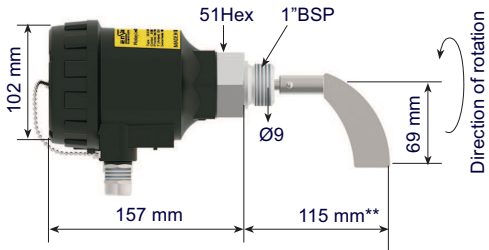

90°C Opt. 150°C
Vertical / Horizontal Mounting
Weight 2,1 kg

DX-ELF 103

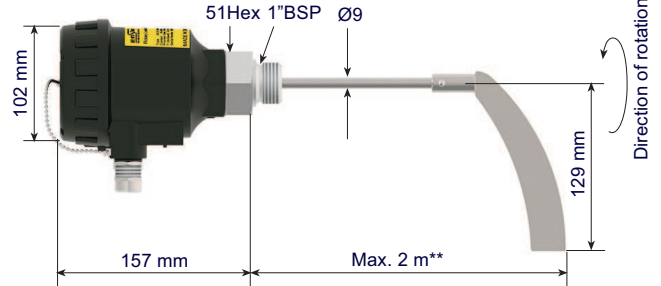

90°C Opt. 150°C
Vertical Mounting
Weight 2,2 kg

DX-ELF 104

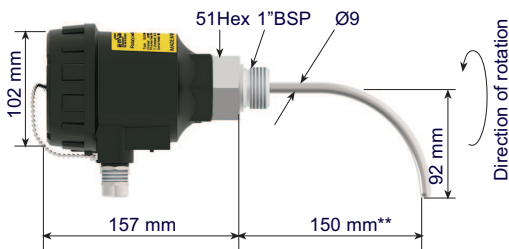

90°C Opt. 150°C
Vertical / Horizontal Mounting
Weight 2,1 kg

DX-ELF 105

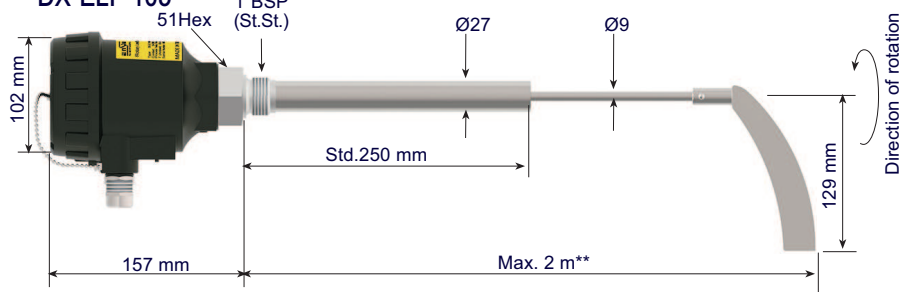

90°C Opt. 150°C
Vertical / Horizontal Mounting
Weight 2,6 kg

** Tolerance +/- 5 mm .

Sample Models :

DX-ELF 106m

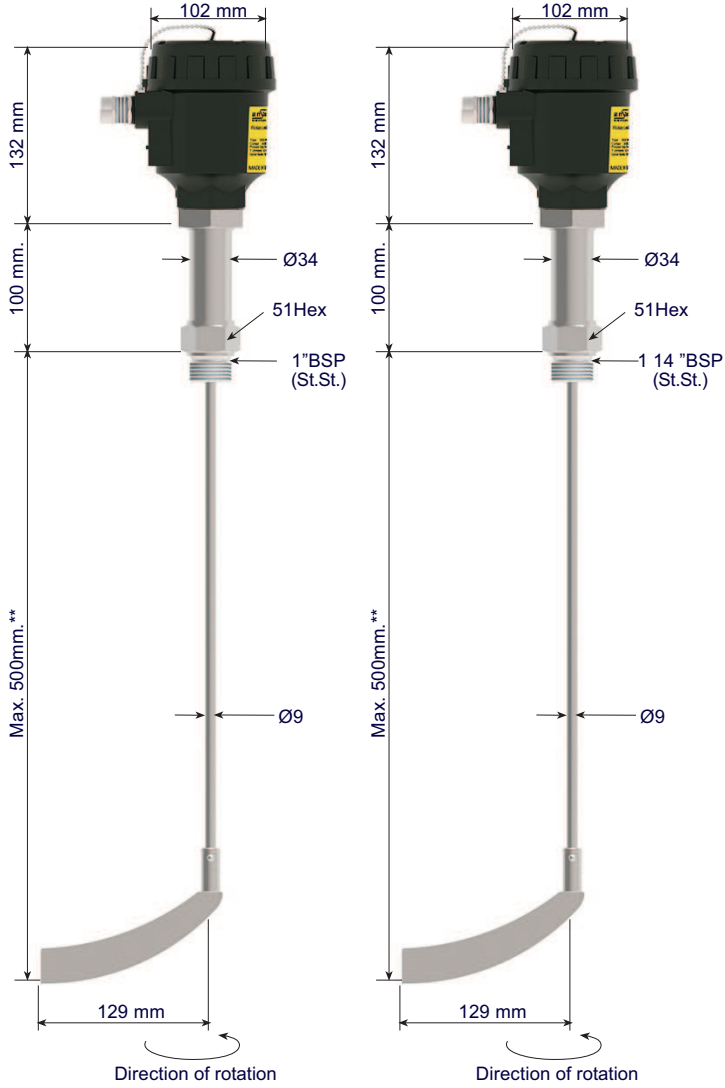

150°C
Vertical / Horizontal Mounting
Weight 2,4 kg

Opt.200°C
Vertical / Horizontal Mounting
Weight 2,4 kg

DX-ELF 106

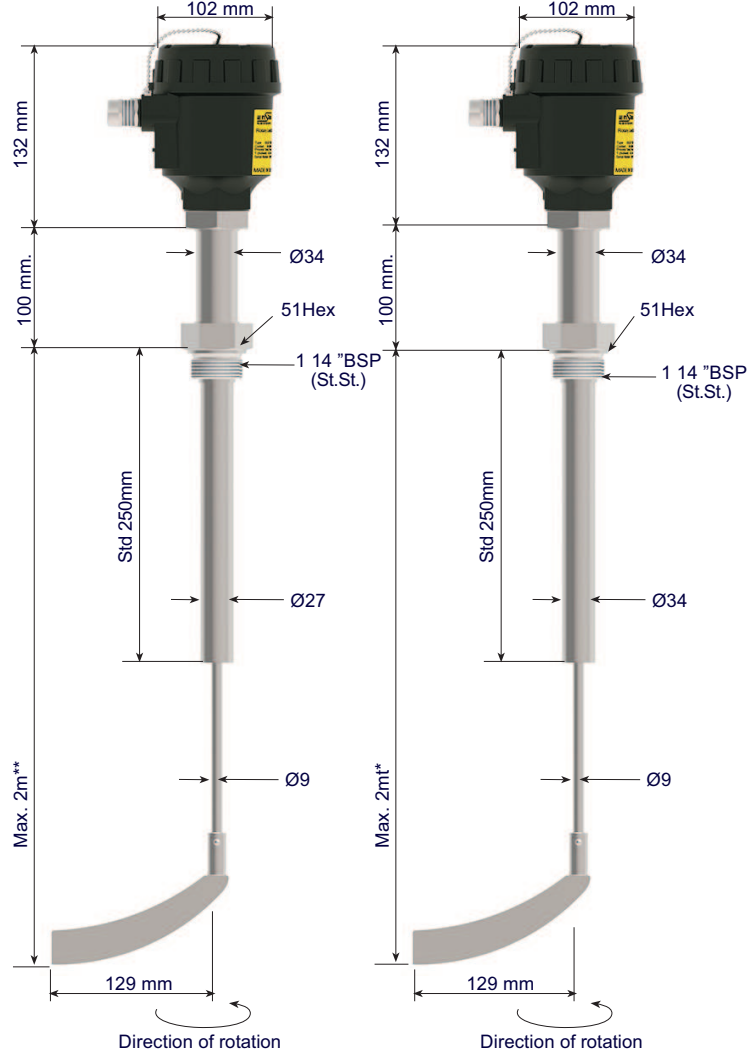

150°C
Vertical / Horizontal Mounting
Weight 2,8 kg

Opt.200°C
Vertical / Horizontal Mounting
Weight 2,8 kg

** Tolerance +/- 5 mm .

Sample Models :

DX-ELF 108

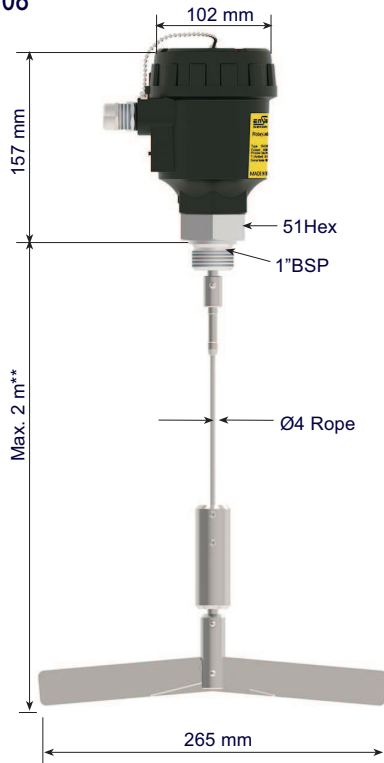

Direction of rotation
90°C Opt. 150°C
Vertical Mounting
Weight 2,7 kg

DX-ELF 109

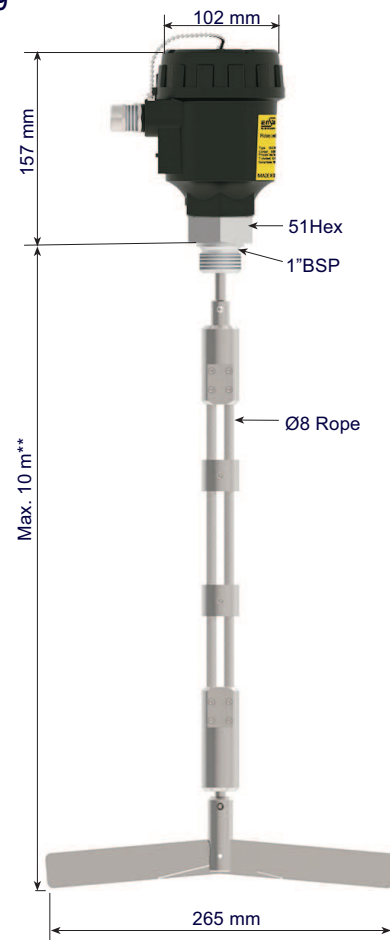

Direction of rotation
90°C Opt. 150°C
Vertical Mounting
Weight 3,4 kg

** Tolerance +/- 5 mm .

2.12. Maximum surface temperature

STD. MODEL	DX-ELF 101 DX-ELF 102	DX-ELF 103	DX-ELF 104 DX-ELF 105	DX-ELF 108 DX-ELF 109	DX-ELF 103p	DX-ELF 106 DX-ELF 106m
Working Temperature	(-)20...(+)90°C				(-)20...(+)60°C	(-)20...(+)150°C
Stand by time before opening the cover	dk.				dk.	dk.
Working temperature in plastic types	(-)20...(+)60°C					

Thermal Protection Insurance.....105°C

(-) 20° C < T environment ≤ (+) 30° C...(+) 60° C		Working temperature :(-) 20...(+) 90° C	
DX-ELF 101 - DX-ELF 102 - DX-ELF 103 - DX-ELF 104 - DX-ELF 105 - DX-ELF 108 - DX-ELF 109			
T Environment MAX. AMBIENT TEMPERATURE ZONE 21 / 1	T Process MAX. PROCESS TEMPERATURE ZONE 20 / 0	T Surface MAX. SURFACE TEMPERATURE	TEMPERATURE CLASS
30° C	90° C	58° C	T6
40° C	90° C	65° C	T6
50° C	90° C	78° C	T6
60° C	90° C	88° C	T5

(-) 20° C < T environment ≤ (+) 30° C...(+) 60° C		Working temperature :(-) 20...(+) 60° C	
DX-ELF 103p			
T Environment MAX. AMBIENT TEMPERATURE ZONE 21 / 1	T Process MAX. PROCESS TEMPERATURE ZONE 20 / 0	T Surface MAX. SURFACE TEMPERATURE	TEMPERATURE CLASS
30° C	60° C	° C	
40° C	60° C	° C	
50° C	60° C	° C	
60° C	60° C	° C	

(-) 20° C < T environment ≤ (+) 30° C...(+) 60° C		Working temperature :(-) 20...(+) 150° C	
DX-ELF 101 - DX-ELF 102 - DX-ELF 103 - DX-ELF 104 - DX-ELF 105 - DX-ELF 106 - DX-ELF 106m - DX-ELF 108 - DX-ELF 109			
T Environment MAX. AMBIENT TEMPERATURE ZONE 21 / 1	T Process MAX. PROCESS TEMPERATURE ZONE 20 / 0	T Surface MAX. SURFACE TEMPERATURE	TEMPERATURE CLASS
30° C	150° C	65° C	T6
40° C	150° C	70° C	T6
50° C	150° C	82° C	T6
60° C	150° C	91° C	T5

(-) 20° C < T environment ≤ (+) 30° C...(+) 60° C		Working temperature :(-) 20...(+) 200° C	
DX-ELF 106 - DX-ELF 106m			
T Environment MAX. AMBIENT TEMPERATURE ZONE 21 / 1	T Process MAX. PROCESS TEMPERATURE ZONE 20 / 0	T Surface MAX. SURFACE TEMPERATURE	TEMPERATURE CLASS
30° C	200° C	50° C	T6
40° C	200° C	54° C	T6
50° C	200° C	64° C	T6
60° C	200° C	80° C	T6

2.12. Paddle Shapes :

Standard Scimitar Paddle
(258mm)

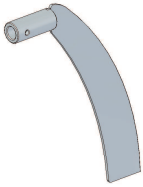

Weigh 105 gr.

Paddle 1 (304 St.St.)
Paddle 2 (316 St.St.)

Mini Scimitar Paddle
(138mm)

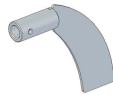

Weigh 75 gr.

Paddle 3 (304 St.St.)
Paddle 4 (316 St.St.)

Double-Baded Collapsible Paddle
(265mm)



Weigh 235 gr.

Paddle 5 (304 St.St.)
Paddle 6 (316 St.St.)

Double-Baded Collapsible Paddle
(540mm)



Weigh 120 gr.

Paddle 11 (Plexiglass)

Cross-Wing Paddle
(105x90mm)

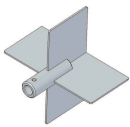

Weigh 185 gr.

Paddle 9 (304 St.St.)
Paddle 10 (316 St.St.)

Cross-Wing Paddle
(148x98mm)

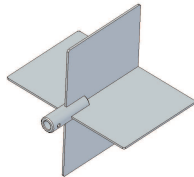

Weigh 515 gr.

Paddle 7 (304 St.St.)
Paddle 8 (316 St.St.)

Single Wing Paddle
(75x35mm)

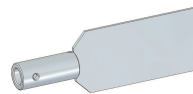

Paddle 12 (304 St.St.)
Paddle 13 (316 St.St.)

Single Wing Paddle
(80x65mm)

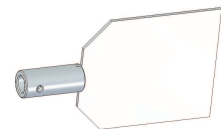

Paddle 14 (304 St.St.)
Paddle 15 (316 St.St.)

Density of examples that can be applicable :

Material	Min.Density (Kg/m ³)	Material	Min.Density (Kg/m ³)
Chopped Corn	550	Metals, Iron Chips	2650
Crushed limestone	1350-1510	Coal Pellet	400-800
Sawdust	50-160	Dry Malt Floor	310
Rubber Floor	400-800	Dry Coarse Coal	560-725
Tea Leaves	195	Grain - Oat	400-560
Shelled Peanut	550-710	Sugary Granule	880
Dusting Powder	730-990	Wheat	400-500
Acrylic Resin	330	Breadstuff	600-800
Wheat flour	480-560	Aquaous Lime Powder	400-500
Cement Dust	1370-1510	Powder PVC	300-600
Silica Sand	1510	Granule PVC	300-600
Lumpy Polypropylene	540-575	Sunflower Marsh	300-500
Roasted Coffee	350-480	Red Pepper	800-1000

2.13. Parts Names :

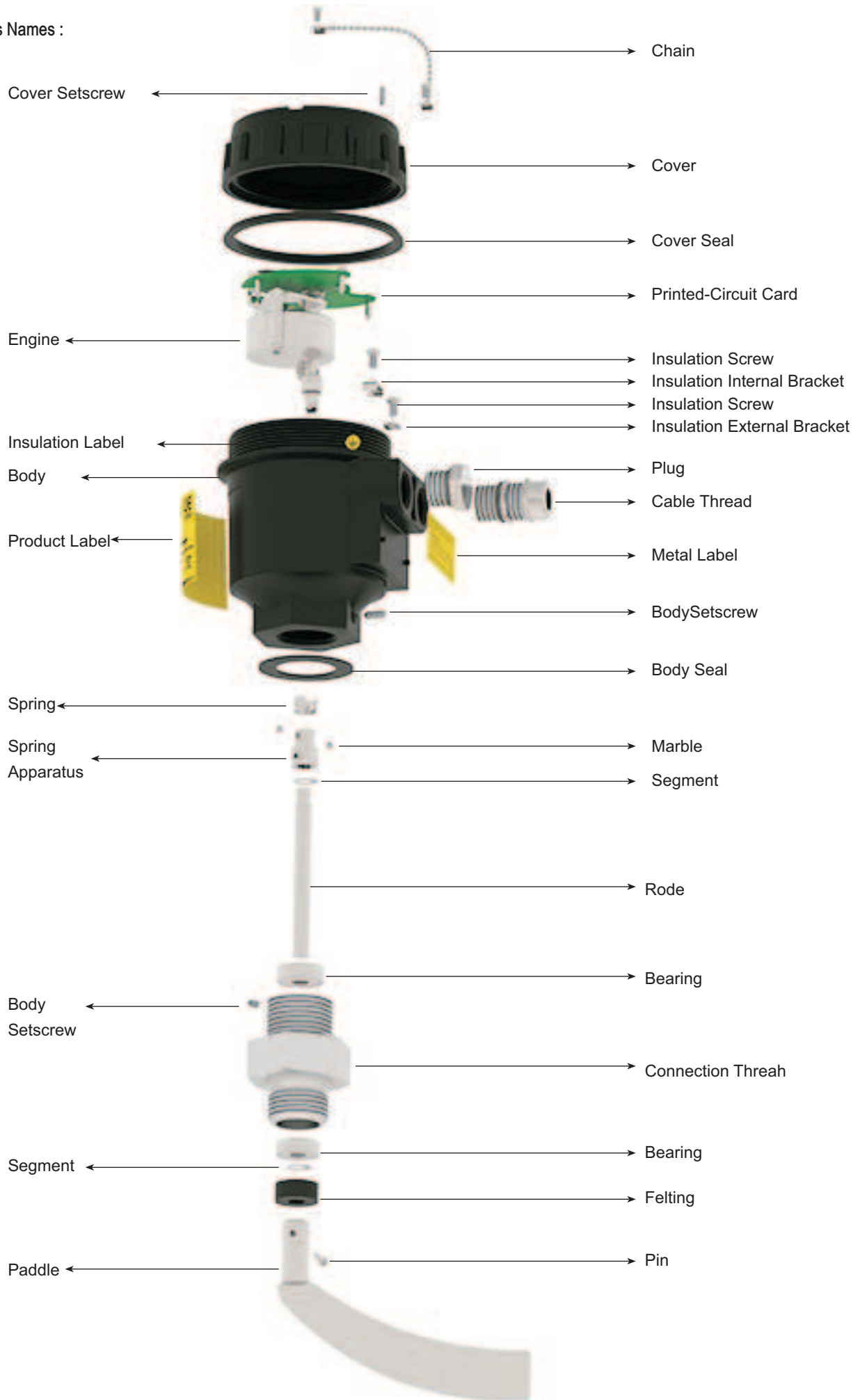

2.14. **Order Form : Please consider sample models when coding**

1 MODEL ELF

Standart.....1

2 CERTIFICATE

None.....0 (EN10204-3-1) Material Certification.....1

3 SHAFT TYPE - (STEM LENGHT)

Standart Shaft - L= 150 mm.....1	Shaft With Extention Tube - L= 2m.(For High Temperature).....6
Mini Shaft - L= 75 mm.....2	Mini-Shaft With Extention Tube - L= 150mm Max.500.....6m
Long Shaft - L= 500 mm3	Extention High Temperature Shaft- L= 2m.(At the design state)..7
Standart Shaft - L= 250 mm.....3p	Rope Shaft - L= 2000 mm).....8
Single Shaft - L= 500 mm4	Reinforced Rope (28 KN) - L= Max.10m.....9
Cable Extented Shaft - L= 500 mm.....5	Special.....x

4 PADDLE TYPE

Without Paddle (184mm)0	Cross-Wing Paddle (210mm).....5
Standart Scimater Paddle (258mm).....1	Cross-Wing Paddle (298 mm).....6
Mini Paddle (138mm).....2	Single Wing Paddle (80x65mm).....7
Double-Baded Collapsible Paddle (265mm).....3	Single Wing Paddle (74x35mm).....8
Double-Baded Collapsible Paddle-Plexiglass(540mm).....4	Special.....x

5 CONNECTION

* 1" BSP Male Thread (Std).....006	1 1/2" BSP Male Thread008
1 1/4" BSP Male Thread007	Special.....x

***Those can be choosen(applicable)only products with 90 Celcius working temprature.**

6 CONNECTION MATERIAL

304 Stainless Steel.....01	Special.....x
316 Stainless Steel.....02	
Aluminium (Std).....31	

7 POWER SUPPLY

24 VDC.....1	220 VAC 50/60Hz +/- %10.....4
24 VAC 50/60 Hz +/- %102	48 VAC 50/60Hz +/- %10.....5
110 VAC 50/60 Hz +/- %10.....3	Special.....x

8 REVOLUTIONS PER MINUTE

5 rpm (Std)1	Special.....x
1,5 rpm2	

9 MATERIAL OF POWDER FEELTING

PTFE Max. 200°C.....	66	Special.....	x
NBR (Std) Max.90°C.....	81		
FPM Maxs. 150°C.....	85		

10 ROLLER

Metal Ball Bearing (Std) 120°C.....	1	Metal Ball Bearing 280°C.....	3
Ceramic Ball Bearing.....	2	Special.....	x

11 HOUSING MATERIALS

Aluminum B20x.....	25	Special.....	x
--------------------	----	--------------	---

12 ELECTRICAL CONNECTION

With Terminal.....	00	Special.....	x
--------------------	----	--------------	---

13 OPTIONAL

None.....	/ 0	Muff 1" BSP 304 St.St.....	/ M1
Reduction 1" BSP - 1 1/4" BSP 304 St.St.....	/ R1	Muff 1 1/4" BSP 304 St.St.....	/ M2
Reduction 1" BSP - 1 1/2" BSP 304 St.St.....	/ R2	Muff 1 1/2" BSP 304 St.St.....	/ M3
Reduction 1" BSP - 1 1/4" BSP 316 St.St.....	/ R3	Muff 1" BSP 316 St.St.....	/ M4
Reduction 1" BSP - 1 1/2" BSP 316 St.St.....	/ R4	Muff 1 1/4" BSP 316 St.St.....	/ M5
Reduction 1" BSP - 1 1/4" BSP ST 37 Steel.....	/ R5	Muff 1 1/2" BSP 316 St.St.....	/ M6
Reduction 1" BSP - 1 1/2" BSP ST 37 Steel.....	/ R6	Muff 1" St 37 Steel.....	/ M7
Reduction 1" BSP - 2" BSP 304 St.St.....	/ R7	Muff 1 1/4" ST 37 Steel.....	/ M8
Flange with muff 110mm 304 St.St.....	/ F1	Muff 1 1/2" ST 37 Steel.....	/ M9
Flange with muff 110mm 316 St.St.....	/ F2	M12 x 5 pin socket (Max. 60 V).....	/ S1
Flange with muff 200mm 304 St.St.....	/ F3	External LED socket.....	/ L1
Flange with muff 200mm 316 St.St.....	/ F4	Change for body - Cover	/ Z1
Protection plate 304 St.St.....	/ K1	Special.....	x
Shelter - (For the outside of the tank) 304 St.St.	/ K2		

Important Note : In high temperature applications , felting and protection material must be selected appropriately.

SAMPLE

DX-ELF 101 - 1 - 006 - 31 - 1 - 1 - 81 - 1 - 02 - 00 / 0

Rotary Level Switch , DX-ELF 101 , Standard Paddle , L=150mm , 1" BSP, 24VDC



WARNINGS !!!

Please pay attention to following matters in order to operate your level switch properly.

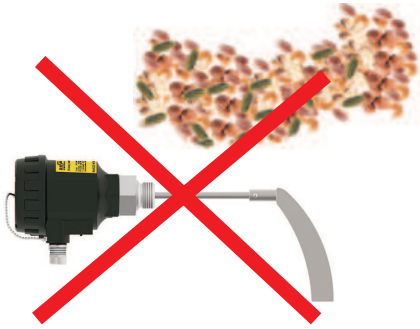

No material shall not drop on the pedal.
Cover the top with guard plate.

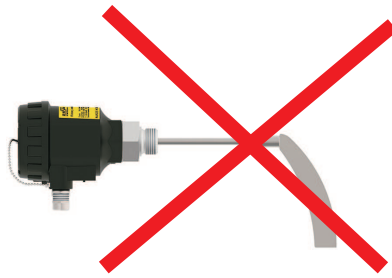

Do not pull the cable strongly,
otherwise the characteristics
might be changed.

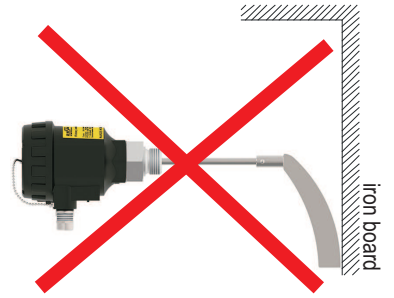

Please keep away from magnetic materials
like iron board ; otherwise the
characteristics might be affected.

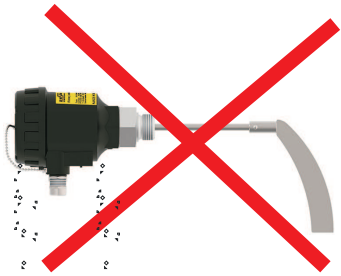

Please do not dip cables
potting into liquids,otherwise
instulation problem may cause..

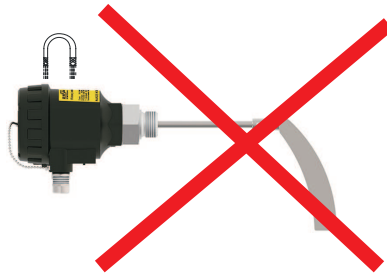

Please keep away from magnetic
field ,otherwise it might
be mis-operated.

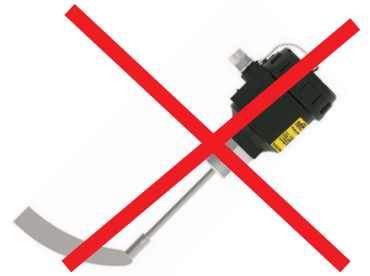

Please do not drop ,
otherwise the characteristics
might be changed..

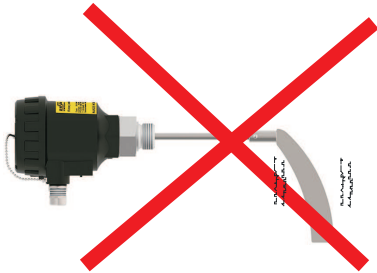

Vibration might be
caused instability.

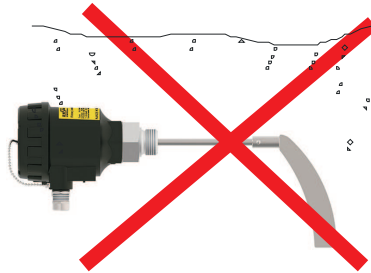

In case vapour splash cable
potting points,insulation
problem may cause.

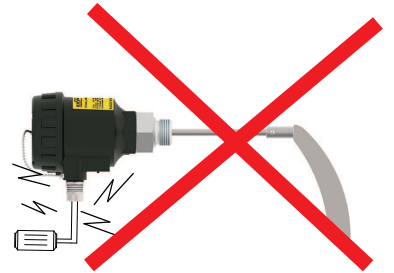

Excess current , to be drawn as
a result of direct connection to motor,
may burn relay of switch

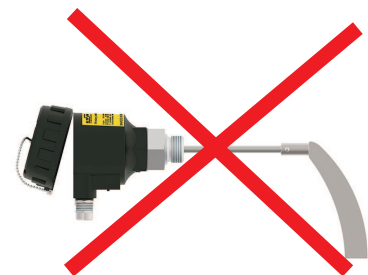

Do not remove the plastic parts
of the bottom of the switch body,
do not loosen.

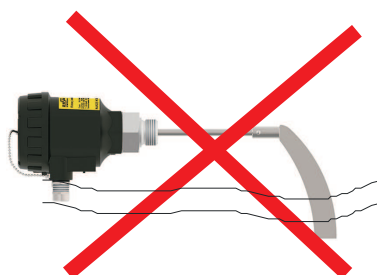

Due not use with materials which
may damage the material.



Do not connect the switch
with inverted polarity.
It characteristics may change.

3. Failure Delection

Failure	Possible cause	Troubleshooting/remedy
Housing is broken	Product fell down or suffered external impact	Notify the authorized service center.
Noises come from the product.	-Bearing may be broken. -Bearing lubrication function may be degraded. -Spring may be broken. -Seal may be broken -Board screws may be loose.	-Notify the authorized service center. -Check and retighten the screws.
Signals no contact or always signals contact	-The contact may be burnt-out. -Installation angle may be wrong. -Socket may be damaged. -Product may be exposed to magnetic field in the environment. -Values higher than operating current and/or voltage are used. -Water has infiltrated in the housing.	-Notify the authorized service center. -Correct the installation angle. -Check the socket connections. -Ensure that the electrical connection points downward. -Check the gaskets.
Unstable operation of the contact	-Product fell down or suffered external impact -Correct spring position is not selected. -Correct palette is not selected.	-Notify the authorized service center. -Contact the manufacturer for palette suitable for the material.
Motor running but no signal is being received.	-The pedal may be dislocated. -The material may not have reached to switch level. -Palette is not selection is not made according to the density of the material.	-Check and reinstall the pedal. -Check if the switch is installed to the right position.

If you find an error, try to eliminate it by using this table or send the instrument to our service address for repair.



The instrument should be repaired only by authorized service! Serial number shall be indicated to the authorized service center.

4. Disassembly of Instrument

Instrument should be disassembled while feeding and pressure is not available!

5. Service

The instrument does not require maintenance. If it is desired, residue accumulated inside should be blown according to kind of fluid and instrument can be cleaned with soft cleaning solutions. Measures should be taken during the disassembly.

6. Re-Calibration

During long period usage of level switch, there might be deviations on measurements. In those cases, recalibration is recommended. Re-calibration could be made by your technical staff or you could send to manufacturer company. According to IEC 60017, ex proof devices must be go through detailed inspection every 3 year from purchase date. Responsibility of inspections are belong to the user (IEC: International Electrotechnical Commission)

7. Repair – Manufacturer Address

If irreparable breakdowns occur, the instrument should be sent to us for repair purpose. Before this, the instrument should be cleaned carefully and packaged so as not to be broken. Furthermore, you should also add a detailed explanation which describes the breakdown while instrument is sent. If your instrument contacts with harmful substances, decontamination report should be also sent additionally. In the event that instrument does not have any decontamination report or our service department has doubts about instrument, repair process will not start until an acceptable report is sent.

If the instrument contacts with hazardous substances, necessary measures should be taken for decontamination!

Service -Manufacturer Company Name and Address:



LONCA PAZ. MAK. SAN. TİC. A.Ş. Piyalepaşa Cad. Stad Sokak No: 29/6 Kasımpaşa - İSTANBUL - TÜRKİYE

Tel: 0212 297 70 14 Faks: 0212 297 70 32 E-Mail: lonca@ensim.com.tr Web: www.ensim.com.tr

8. Disposal

The instrument should be disposed according to 2002/96/EC and 2003/108/EC European Directives (waste electrical and electronic instruments).

Waste electrical and electronic equipment should not be mixed with domestic wastes!



If the instrument has contacted with harmful substances, special attention should be paid for its disposal!

9. Terms of Warranty

The instrument has warranty legally for 24 months after delivery date. Warranty demands are not accepted in case of inappropriate operation, damage on the instrument or any modification on the instrument.

10. Terms of Return

In the return of materials, user should send an open list related to damage or problem, malfunction of the material to be returned or its operation in the different modification, with the instrument. If it is required to return the material, used in the dangerous, corrosive or toxic fluid, in this case, used part should be cleaned very carefully. Security of staff should be ensured. All products to be returned should be sent to our company address, which we have stated.