



Product info sheet no. C 4.3 - ball tap Humidity / temperature sensors

Pressure resistant compact sensors in the stainless steel casing can be employed up to 25 bar or up to 10 bar with ball valve

Description

MELA®-humidity/temperature sensors of the VRx.D series are compact humidity or humidity/temperature sensors in a high-grade steel housing, with a connecting head and screw-type clamping ring fitting. They are employable up to 25 bar by 3/8" thread or series VRx.D.-KH employable up to 10 bar by means of ball valve.

All the sensors in the series are equipped with a ZE 13-type sintered high-grade steel filter as standard.

They have been specially developed for use in extreme conditions and are suited to measure relative humidity or relative humidity and temperature in air and other non-aggressive gases.

Use of capacitive humidity sensor elements is a guarantee of:

- high long-term stability
- almost linear characteristic curve
- good dynamic performance
- resistance to dew formation
- small hysteresis.

Technical data

Humidity

measuring range 0...100%rh
 accuracy (MR 5...95%rh at 10...40°C) ±2%rh
 at <10°C, >40°C <0.1%/K additional
 response time (at calm air) < 20 s

Temperature

measuring element (DIN EN 60751) Pt 100 class B
 measuring range -30...+70°C
 accuracy
 0...1V (-27...70°C) ±0.2 K
 0...10V (-29...70°C) ±0.2 K
 4...20mA ±0.4 K
 at <10°C, >40°C ±0.007 K/K additional

Other data

ambient temperature -40...+80°C
 mode of protection sensor/electronics IP 40/IP 65

operating voltage:

current-output 12...30V DC
 voltage-output (0...10V) 15...30V DC
 voltage-output (0...1V) 6...30V DC

load resistance

0...10V ≥10kΩ
 0...1V ≥2 kΩ

load (current-output) acc. diagram

power consumption

0...10V, 2 x 0...1V < 5 mA
 0...1V < 1 mA

minimum air speed across the sensor ≥0.5 m/s

self-heating coefficient Pt 100 (v=2 m/s in air) 0.2 K/mW

directive about electromagnetic compatibility **2004/108/EG**

DIN EN 61326-1 issue 10/06

DIN EN 61326-2-3 issue 05/07

Material sensor part high-grade steel

connecting head pressure die casting of alu

measured variable	output	series VR with connecting head up to 25 bar	series VR...-KH with ball valve up to 10 bar, replaceable under pressure
r. F. rel. humidity	0...1 V	FVR1.D/5	FVR1.D/5-KH
	0...10 V	FVR2.D/5	FVR2.D/5-KH
	4...20 mA	FVR3.D/5	FVR3.D/5-KH
r.h. + Pt100	0...1 V+Pt100	CVR1.D/5	CVR1.D/5-KH
	0...10 V+ Pt100	CVR2.D/5	CVR2.D/5-KH
	4...20 mA+Pt100	CVR3.D/5	CVR3.D/5-KH
r.h. + t	2 x 0...1 V	KVR1.D/5	KVR1.D/5-KH
	2 x 0...10 V	KVR2.D/5	KVR2.D/5-KH
	2 x 4...20 mA	KVR3.D/5	KVR3.D/5-KH
T temperature	0...1 V	TVR1.D/5	TVR1.D/5-KH
	0...10 V	TVR2.D/5	TVR2.D/5-KH
	4...20 mA	TVR3.D/5	TVR3.D/5-KH
	Pt100	TVR5.D/5	TVR5.D/5-KH

Special versions available on request

Humidity working range depending on temperature

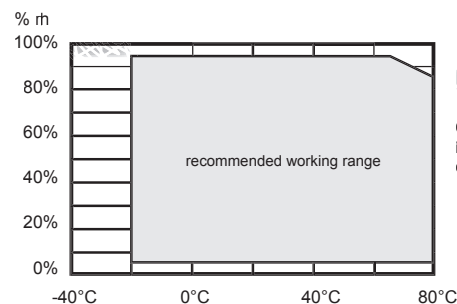

User instructions

Install the **MELA®-humidity / temperature sensors** at a place in the room, plant or equipment where characteristic levels of humidity occur. Avoid installing them close to heaters or windows or against outside walls.

The specified minimum air speed and - with current output - the load according to the operating voltage (diagram) should be complied with. Deviations may lead to additional measuring faults resulting of the self-heating of the sensor (clocked operation will help to avoid this).

The sensor can be installed in any position. However, do avoid positions where water can enter. Dew formation and splashes do not damage the sensor, but can result in faulty measurements until all the moisture on and directly around the sintered high-grade steel filter has dried up.

Dust does not cause any harm to the humidity sensor, however, it affects the dynamic performance.

If there is an excessive build-up of dust, carefully unscrew the protective basket and rinse it out. Do not touch the highly sensitive sensor element.

In order to avoid corrupted measurement readings, only screw the protective basket back on when it is completely dry.

In order to maintain interference immunity in accordance with EN 61326 while in use, we recommend to use a shielded cable (type recommended: **8x AWG 26 C UL, order no. 5339**) for connection of the VR sensors and have it fitted correctly into the sensor's EMC cable gland by a qualified electrician.

Please consult the „*application instructions for the sensing elements*“ (product info sheet no. A 1) or check with the manufacturer for further information which you need to bear in mind when using humidity sensors with capacitive sensing elements.

Load of current output

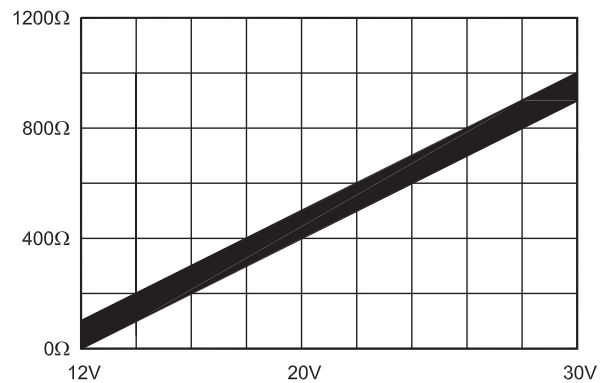

Dimensions VR series

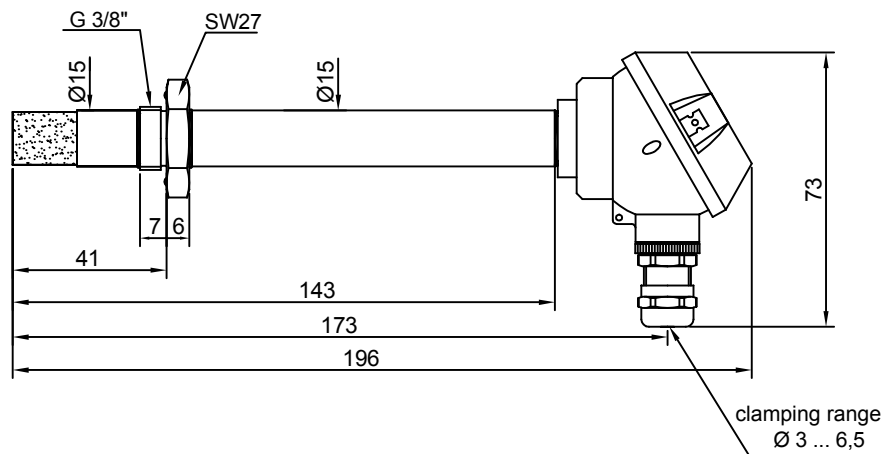

Sensor presented in end setting

Sensor presented in final position

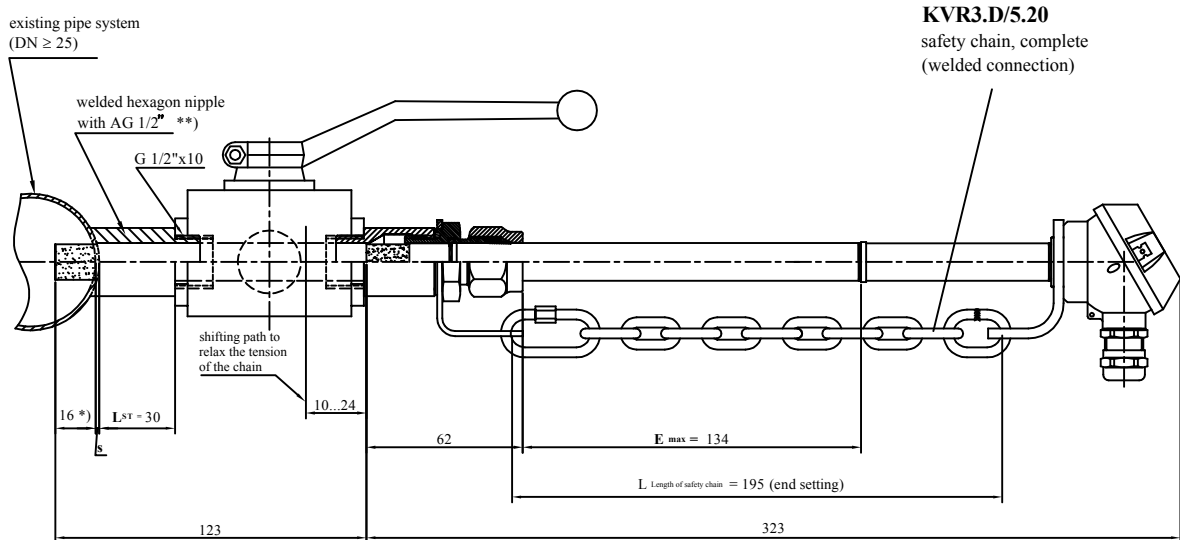

Sensor presented in measuring position

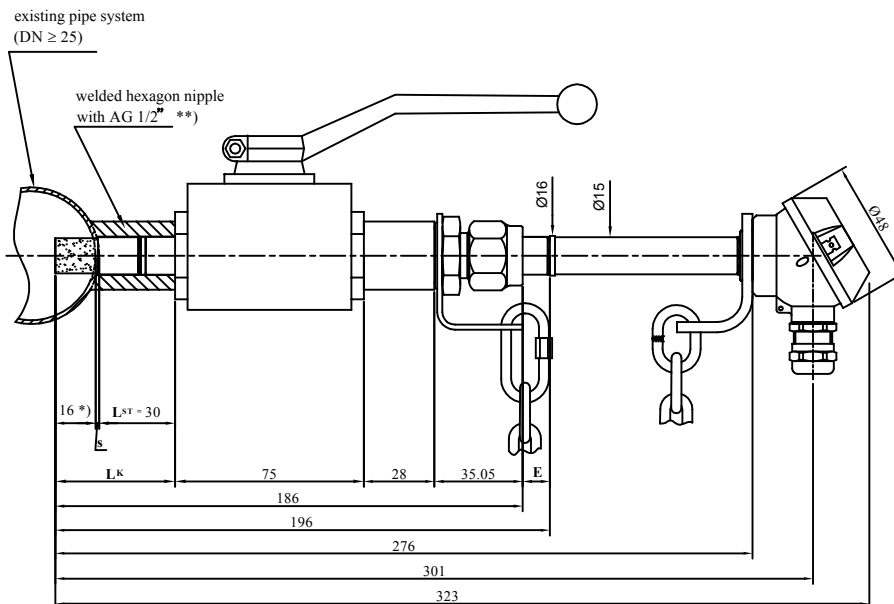

Key:

- L_{ST}: Recommended length of the hexagon nipple 30 mm
- L_K: emersion length off the ball valve (measuring position)
- S: wall thickness of pipe
- E: setting length sensor tube E_{measuring position} = 12 - s
- *) Recommended minimum immersion depth of the sensor tube = 16 mm
- ***) welded hexagon nipple with AG 1/2" is not scope of delivery !
(Information drawing available on request)

Pay attention to the safety information:

When the sensor is employed, first close the safety chain before the ball valve is opened.

Only move the sensor in an axial direction and do not twist it!

When the sensor is uninstalled, only close the ball valve when the safety chain is completely stretched out (compare illustration: final position)!

Connection diagram

Humidity/-temperature sensors

Pressure resistant compact sensors
in a stainless steel casing

series VR.D

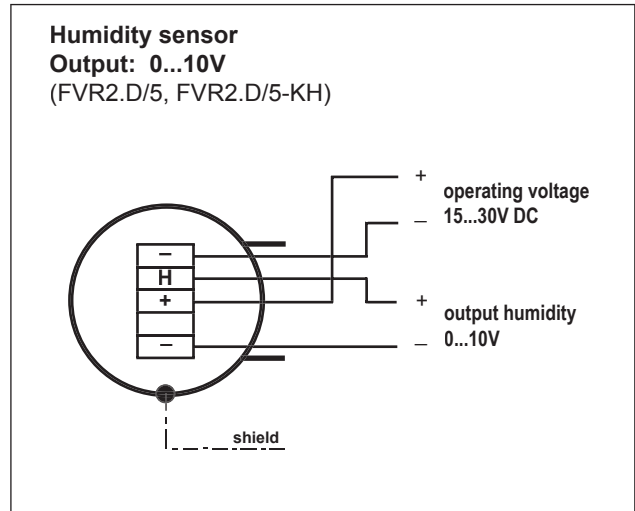
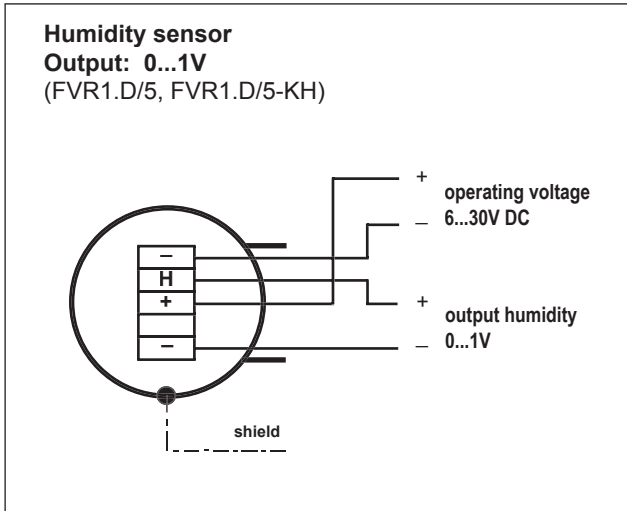

The electrical connection must only be carried out by properly qualified personnel.

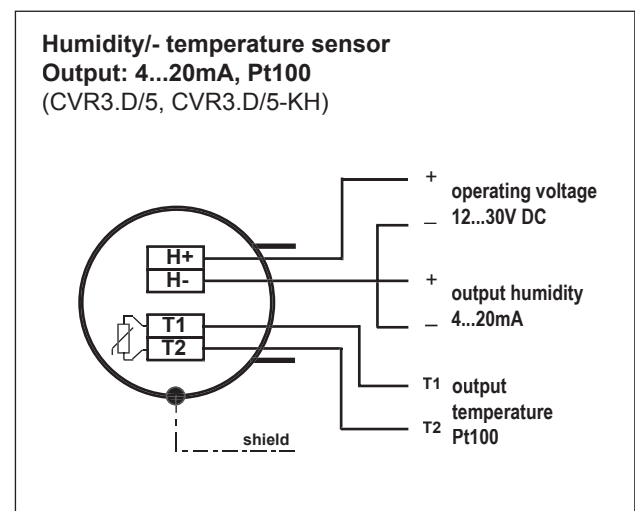
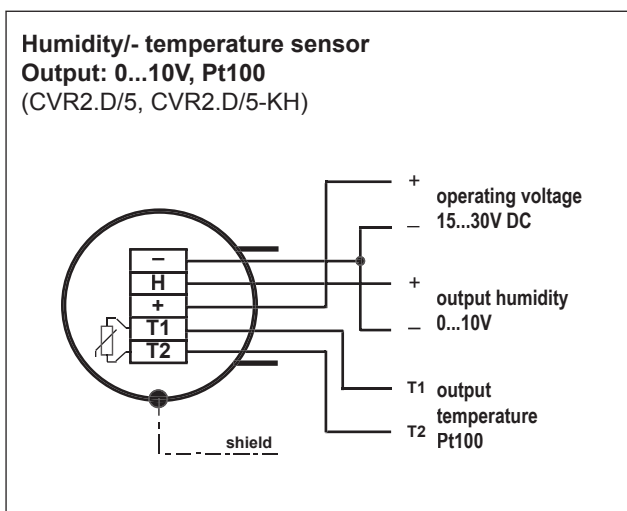
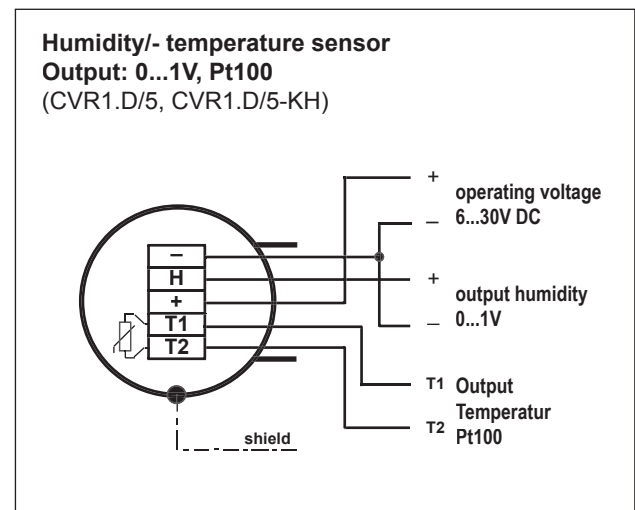
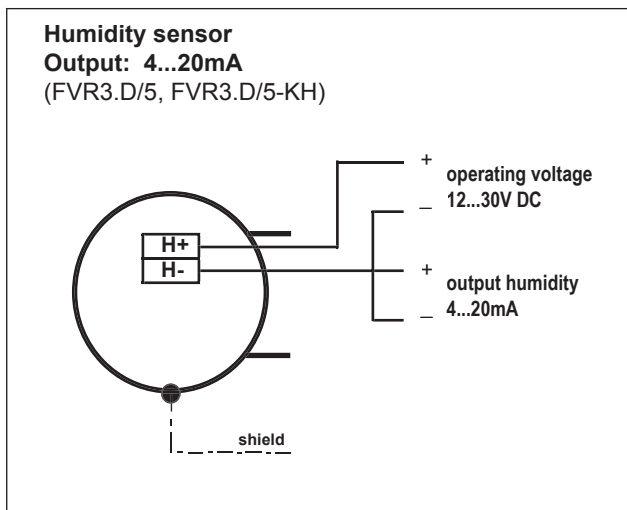

Connection diagram

Humidity/-temperature sensors

Pressure resistant compact sensors
in a stainless steel casing

series VR.D

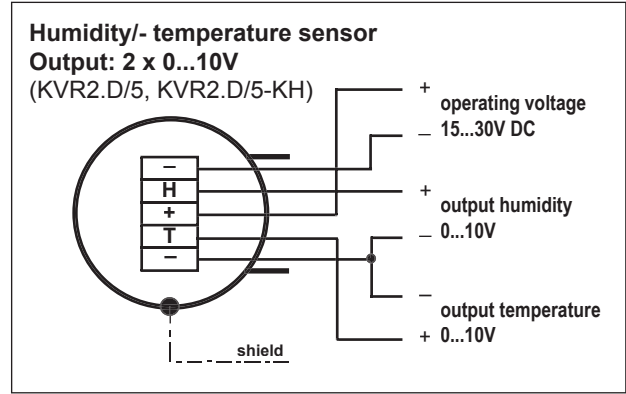
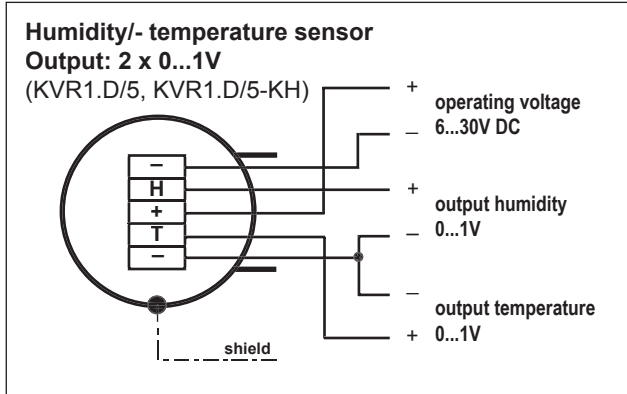

The electrical connection must only be carried out by properly qualified personnel.

