



Description of the sensor

The exchangeable digital sensor PMU-P is equipped with the tried and tested Mela® humidity measuring element FE09/4. Protected by a PTFE pocket filter, the measuring element measures the air humidity. The pocket filter consists of porous vapour-permeable material and protects the sensor element from most dirt, dust and pollutants. The electronics and the plug contacts on the back are extrusion-coated with plastic to make them watertight.

The capacitive Mela® humidity measuring element, produced using thin-film technology, consists of a base plate, on which the electrodes are housed, and a hygroscopic polymer layer above it. The hygroscopic polymer layer absorbs water molecules from the medium to be measured (air) or releases them, thereby altering the capacity of the condenser.

The electronics sets off the humidity values measured in this way against the calibration values it has stored and emits them via the plug contacts in the form of calibrated, digital ASCII protocol. The sensor head is also equipped with a temperature probe Pt1000 1/3DIN which is used for both acquiring the air temperature and also for temperature compensation in the humidity measurement by the PMU-P.

The PMU-P measuring heads are calibrated and thus enable an easy replacement. Replaced measuring heads can be recalibrated in the factory.

Please consult the "application instructions for the sensing elements" (product info sheet no. A 1) or check with the manufacturer for further information which you need to bear in mind when using humidity sensors with capacitive sensing elements.

¹⁾ Ex works. Depending on the specific range of application a regular recalibration of the sensor head (PMU-P) has to be effected.

²⁾ Higher accuracies on request.

Digital Humidity-Temperature Sensor PMU-P

Order No. 620101023594

with asynchronous ASCII transmission protocol, calibrated for relative humidity and temperature in exchangeable, plug-in design.

Technical Data

Humidity

measuring range 0..100%rh
 measuring accuracy 10...90%rh at 25°C ±1,5%rh ¹⁾²⁾
 at <10%rh or >90%rh ±2%rh
 at <10°C or >40°C ±0,05%rh/K additional
 resolution 0,01%rh (read out)
 hysteresis < 1%rh
 protection against dust PTFE pocket filter

Temperature

measuring element Pt1000 1/3DIN
 measuring range -40...+85°C
 measuring accuracy ±0,15 K at 25°C
 resolution 0,01K (read out)
 influence of temperature (TK) <0,005 K/K

General

permissible ambient temperature -20...+70°C
 response time t_{63} at $v=2\text{m/s}$ with PTFE-pocket filter < 15 s
 protective system sensor IP20
 protective system plug IP40
 measuring medium air, pressureless, non-aggressive
 Vcc 3.3VDC
 output ASCII (Galltec-protocol)
 housing plastic
 consumption of electronics < 5 mA
 maximum air speed 15 m/s
 mounting position optional
 electromagnetic compatibility..... EN 61326-1
 contacting 4Pin female socket, series 719 from Binder

Accuracy of humidity in %rh at 25°C

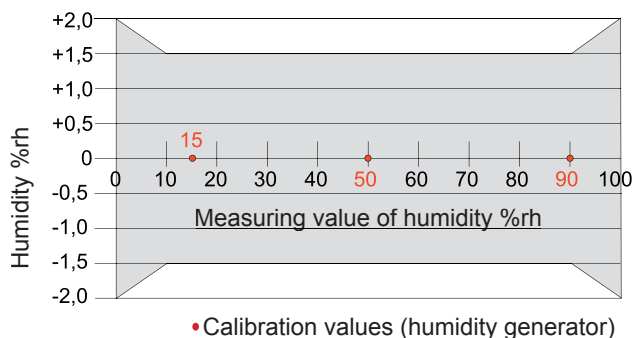

ESD protection advice

All PM15P sensors are made up of a PMO15P transmitter with a PMU-P sensor head and contain components which can be damaged by the effects of electrical fields or by charge equalisation when touched. This is why the PMU-P sensor heads, that can be supplied separately and that are suitable for being exchanged on location, are packaged in conductive, reusable ESD protected bags.

The following protective measures must be taken when exchanging a PMU-P sensor head on the PMO15P transmitter:

- Before unpacking the PMU-P sensor head, ensure electrical potential equalisation between you and your environment.
- Pay particular attention to ensuring that this potential equalisation is maintained while you are exchanging the PMU-P sensor head.
- Only store or transport the PMU-P sensor head in the ESD protective bag supplied, or in comparable packaging

Working range humidity and temperature

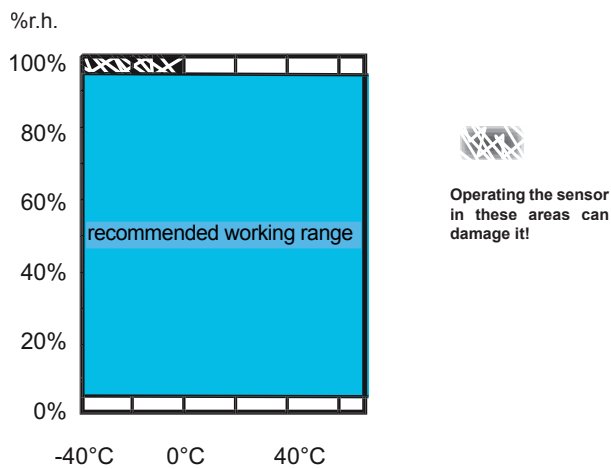

Dimensions and connection diagramm

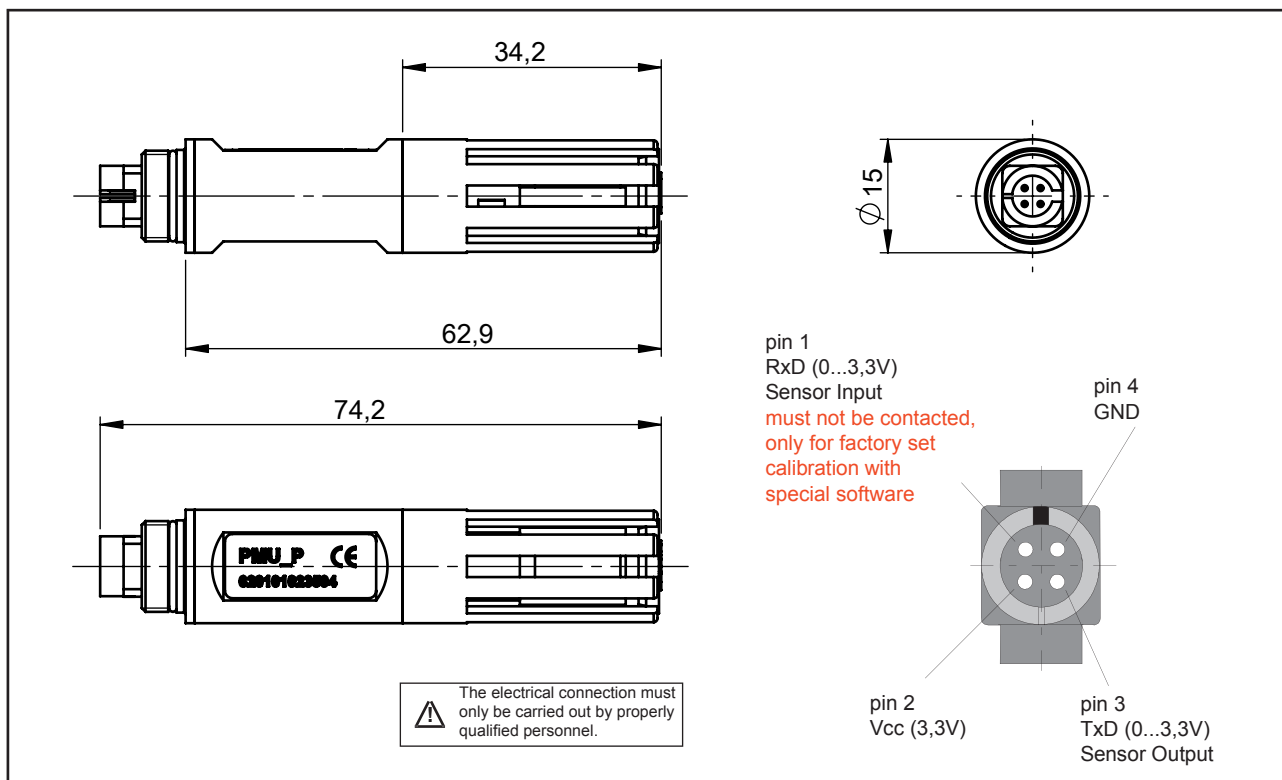

Function and implementation of the digital humidity temperature sensor PMU-P

The exchangeable digital measuring head measures the current temperature and the relative humidity in the direct surroundings.

Output

After contacting and supply via Vcc & GND, the measuring head automatically transmits the measurement protocol via the TxD pin. Every 3-4 seconds the respective current measurement value is re-issued at 9600 Baud. Between the individual measurement protocols (ASCII output), the TxD pin is at 3.3V DC (High Level).

Symbol	Parameter	Min	Max
Vcc	Supply Voltage	3,2 V	3,4 V
Vss	Supply Voltage GND	0 V	0 V
Vol	Output low voltage	Vss	Vss + 0,6V
Voh	Output high voltage	Vcc - 0,6V	Vcc
Ioh	Output source current		0,5mA at Vcc = 3,3V
Iol	Output sink current		0,5mA at Vcc = 3,3V

The above table shows the electrical signals of the digital sensor head PMU-P. The customer must provide a stable, regulated distribution voltage of +3.3V DC.

Notes on ASCII protocol

start of protocol	end of protocol	separation sign
@	"CR" and "LF"	“.” “ ;”

The measurement data is sent in the measurement phase as ASCII-protocol on the RxD-pin:

@T	<sign>	<temperature>	<alarm-code>	F	<humidity>	<alarm-code>	<serial number>	<check-sum>	<CR>	<LF>
----	--------	---------------	--------------	---	------------	--------------	-----------------	-------------	------	------

Example:

@T; + 021.37; A00; F; 038.92; A00; 00000121; 38 control character control character
Carriage Return Line Feed

The check sum is calculated as follows:

$$\text{check sum} = 255 - (\sum_{\text{dez}} \% 256) = \text{Check sum}_{\text{dez}} = \text{Check sum}_{\text{hex}}$$

Example:

$$\text{check sum} = 255 - (1991 \text{ Modulo } 256) = 255 - 199 = 56 = 38_{\text{hex}}$$

The check sum is not transmitted as a hexadecimal character with 1 byte, but is translated into readable digits with 2 bytes. Through the comparison of the transmitted check sum with a check sum calculated at the read-out point, the user has the opportunity to check whether the transmission of the data is error-free.

Alarm codes:

Temperature channel:	Humidity channel:
A00 = no alarm, the temperature value is within the limits	A00 = no alarm, the humidity value is within the limits
A01 = temperature measurement range exceeded	A01 = humidity measurement range exceeded (=100% rh)
A02 = below temperature measurement range	A02 = below humidity measurement range (= 0% rh)
A03 = no sensor signal	A03 = no sensor signal
A04 = short circuit at PT1000 (resistance < 500 Ω)	A04 = humidity sensor defective

Please note:

- > Short leads (max. 1m) between PMU-P and the analysis electronics (provided by customer);
- > PMU-P must be contacted, powered and analysed via hardware and software by customer;
- > The PMU-P is not a „stand alone“ device and must be checked together with the analysis electronics in accordance with the EMC guidelines;
- > The PMU-P does not have an internal polarity reversal protection. Please ensure that the plug contact is only connected to the correct voltage level;

Connection settings

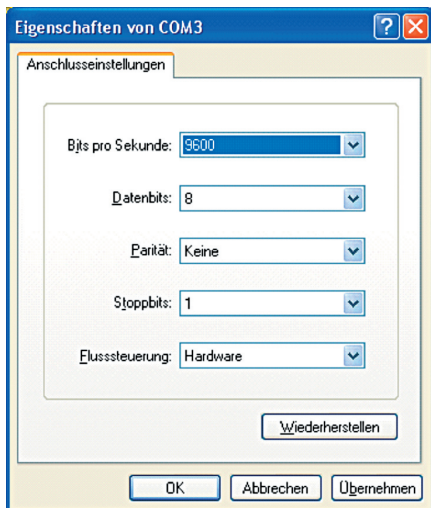

Output via the Hyper Terminal



In connection with a separate signal level converter (RS232), the PMU-P can be read via the Hyper Terminal programme in Windows. The picture below shows the character string of the data issued by the PMU-P.

Output via Visual PMU

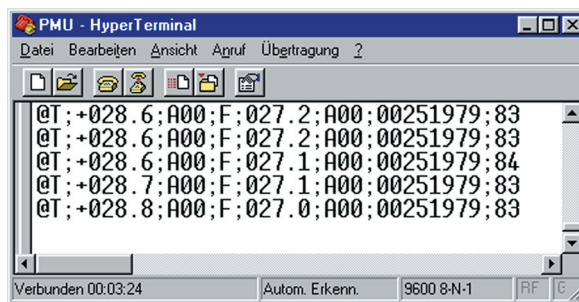
For recording data and for online display purposes, the visualisation programme „Visual PMU“ by Galltec+Mela is available.



Connector versions for contacting the PMU-P

Binder No.	Version	Model	
09-9766-20-04	female	Soldered connection for printed-circuit boards	
09-9766-30-04	female	solder termination	
09-9764-70-04	female	cable connector with strain relief	
09-9764-00-04	female	cable connector without strain relief	